

Properties

Connection 1	metric cylindrical outer thread
Sealing form 1	Shape E
Connection 2	metric cylindrical outer thread
Sealing form 2	24° inner cone
Design	Screw-in fitting
Construction	straight
Standard	DIN 2353 ISO 8434-1
Scope of supply	Socket (without union nut and cutting ring)
Material	Steel
Surface	electro galvanised

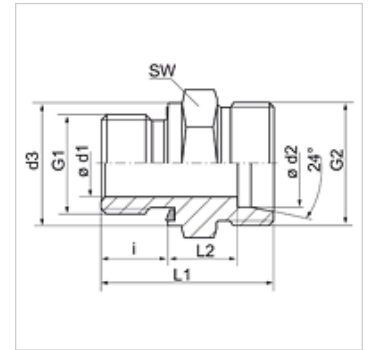

Note

Information about fitting, installation, pressure loads and permissible operating temperatures can be found in the technical information for pipe fittings.

Item

Identification	Series	Operating pressure	Ø d2 (mm)	G1	G2	Ø d3 (mm)	i (mm)	L1 (mm)	L2 (mm)	AF (mm)
XVM NW 04 HL ED	L	PN 315	6	M 10 x 1	M 12 x 1.5	13,9	8	23,5	8,5	14
XVM NW 04 HL 12 ED	L	PN 315	6	M 12 x 1.5	M 12 x 1.5	16,9	12	28,0	9,0	17
XVM NW 06 HL ED	L	PN 315	8	M 12 x 1.5	M 14 x 1.5	16,9	12	29,0	10,0	17
XVM NW 06 HL 14 ED	L	PN 315	8	M 14 x 1.5	M 14 x 1.5	18,9	12	29,0	10,0	19
XVM NW 06 HL 16 ED	L	PN 315	8	M 16 x 1.5	M 14 x 1.5	21,9	12	30,5	11,5	22
XVM NW 06 HL 18 ED	L	PN 315	8	M 18 x 1.5	M 14 x 1.5	23,9	12	30,5	11,5	24
XVM NW 08 HL ED	L	PN 315	10	M 14 x 1.5	M 16 x 1.5	18,9	12	30,0	11,0	19
XVM NW 08 HL 10 ED	L	PN 315	10	M 10 x 1	M 16 x 1.5	-	-	-	-	-
XVM NW 08 HL 12 ED	L	PN 315	10	M 12 x 1.5	M 16 x 1.5	16,9	12	30,0	11,0	19
XVM NW 08 HL 16 ED	L	PN 315	10	M 16 x 1.5	M 16 x 1.5	21,9	12	31,5	12,5	22
XVM NW 08 HL 18 ED	L	PN 315	10	M 18 x 1.5	M 16 x 1.5	23,9	12	31,5	12,5	24
XVM NW 08 HL 22 ED	L	PN 315	10	M 22 x 1.5	M 16 x 1.5	26,9	14	35,0	14,0	27
XVM NW 10 HL ED	L	PN 315	12	M 16 x 1.5	M 18 x 1.5	21,9	12	31,5	12,5	22
XVM NW 10 HL 14 ED	L	PN 315	12	M 14 x 1.5	M 18 x 1.5	18,9	12	31,5	12,5	22
XVM NW 10 HL 18 ED	L	PN 315	12	M 18 x 1.5	M 18 x 1.5	23,9	12	32,0	13,0	24
XVM NW 10 HL 22 ED	L	PN 315	12	M 22 x 1.5	M 18 x 1.5	26,9	14	35,0	14,0	27
XVM NW 13 HL ED	L	PN 315	15	M 18 x 1.5	M 22 x 1.5	23,9	12	32,5	13,5	24
XVM NW 13 HL 16 ED	L	PN 315	15	M 16 x 1.5	M 22 x 1.5	21,9	12	32,0	13,0	24
XVM NW 13 HL 22 ED	L	PN 315	15	M 22 x 1.5	M 22 x 1.5	26,9	14	35,0	14,0	27
XVM NW 16 HL ED	L	PN 315	18	M 22 x 1.5	M 26 x 1.5	26,9	14	36,0	14,5	27
XVM NW 16 HL 18 ED	L	PN 315	18	M 18 x 1.5	M 26 x 1.5	23,9	12	33,5	14,0	27
XVM NW 20 HL ED	L	PN 160	22	M 26 x 1.5	M 30 x 2	31,9	16	40,0	16,5	32
XVM NW 20 HL 22 ED	L	PN 160	22	M 22 x 1.5	M 30 x 2	26,9	14	38,0	16,5	32
XVM NW 25 HL ED	L	PN 160	28	M 33 x 2	M 36 x 2	39,9	18	43,0	17,5	41
XVM NW 32 HL ED	L	PN 160	35	M 42 x 2	M 45 x 2	49,9	20	48,0	17,5	50
XVM NW 40 HL ED	L	PN 160	42	M 48 x 2	M 52 x 2	54,9	22	52,0	19,0	55
XVM NW 03 HS ED	S	PN 630	6	M 12 x 1.5	M 14 x 1.5	16,9	12	32,0	13,0	17
XVM NW 04 HS ED	S	PN 630	8	M 14 x 1.5	M 16 x 1.5	18,9	12	34,0	15,0	19
XVM NW 06 HS ED	S	PN 630	10	M 16 x 1.5	M 18 x 1.5	21,9	12	34,5	15,0	22
XVM NW 08 HS ED	S	PN 630	12	M 18 x 1.5	M 20 x 1.5	23,9	12	36,5	17,0	24
XVM NW 08 HS 22 ED	S	PN 400	12	M 22 x 1.5	M 20 x 1.5	26,9	14	39,0	17,5	27
XVM NW 10 HS ED	S	PN 630	14	M 20 x 1.5	M 22 x 1.5	25,9	14	41,0	19,0	27
XVM NW 13 HS 18 ED	S	PN 400	16	M 18 x 1.5	M 24 x 1.5	23,9	12	38,5	18,0	27
XVM NW 13 HS ED	S	PN 400	16	M 22 x 1.5	M 24 x 1.5	26,9	14	41,0	18,5	27
XVM NW 16 HS ED	S	PN 400	20	M 27 x 2	M 30 x 2	31,9	16	47,0	20,5	32
XVM NW 20 HS ED	S	PN 400	25	M 33 x 2	M 36 x 2	39,9	18	53,0	23,0	41
XVM NW 25 HS ED	S	PN 400	30	M 42 x 2	M 42 x 2	49,9	20	57,0	23,5	50
XVM NW 32 HS ED	S	PN 315	38	M 48 x 2	M 52 x 2	54,9	22	64,0	26,0	55

Series: LL = Very light L = Light S = Heavy - PN = Nominal pressure PB = Max. operating pressure - Ø d2 = External pipe diameter



Product versions

XVM ED VA Screw-in fitting, Stainless steel

VM ED Screw-in fitting, Steel

Spare parts

WD Soft seal for ED fittings