

UEM B V

Union nut for flange connection

Properties

Design Union nut for flare connection, 10°

Material Steel

Surface electro galvanised

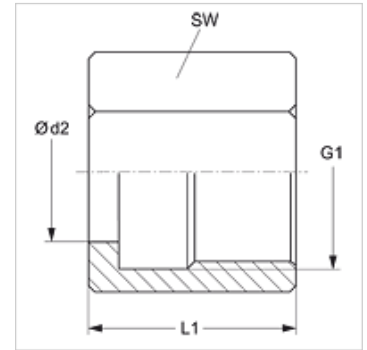
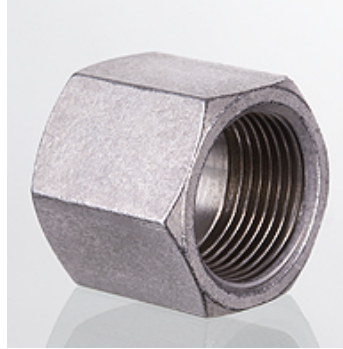

Item

Identification	Series	Operating pressure	Ø d2 (mm)	G1	L1 (mm)	AF (mm)
UEM NW 04 LB V	L	PN 315	6	M 12 x 1.5	17,8	14
UEM NW 06 LB V	L	PN 315	8	M 14 x 1.5	17,8	17
UEM NW 08 LB V	L	PN 315	10	M 16 x 1.5	18,8	19
UEM NW 10 LB V	L	PN 315	12	M 18 x 1.5	18,8	22
UEM NW 13 LB V	L	PN 315	15	M 22 x 1.5	20,3	27
UEM NW 16 LB V	L	PN 315	18	M 26 x 1.5	21,3	32
UEM NW 20 LB V	L	PN 160	22	M 30 x 2	24,0	36
UEM NW 25 LB V	L	PN 160	28	M 36 x 2	25,0	41
UEM NW 32 LB V	L	PN 160	35	M 45 x 2	28,0	50
UEM NW 40 LB V	L	PN 160	42	M 52 x 2	28,0	60
UEM NW 04 SB V	S	PN 630	8	M 16 x 1.5	20,0	22
UEM NW 06 SB V	S	PN 630	10	M 18 x 1.5	21,5	24
UEM NW 08 SB V	S	PN 630	12	M 20 x 1.5	21,5	27
UEM NW 10 SB V	S	PN 630	14	M 22 x 1.5	26,0	30
UEM NW 13 SB V	S	PN 400	16	M 24 x 1.5	26,0	30
UEM NW 16 SB V	S	PN 400	20	M 30 x 2	30,5	36
UEM NW 20 SB V	S	PN 400	25	M 36 x 2	38,0	46
UEM NW 25 SB V	S	PN 400	30	M 42 x 2	39,0	50
UEM NW 32 SB V	S	PN 315	38	M 52 x 2	46,0	60

Series: LL = Very light L = Light S = Heavy - PN = Nominal pressure PB = Max. operating pressure - Ø d2 = External pipe diameter