

## Properties

<b>Connection 1</b>	metric cylindrical outer thread
<b>Sealing form 1</b>	Shape F
<b>Connection 2</b>	metric cylindrical outer thread
<b>Sealing form 2</b>	24° inner cone
<b>Design</b>	Screw-in fitting
<b>Construction</b>	straight
<b>Standard</b>	ISO 8434-1
<b>Scope of supply</b>	Socket (without union nut and cutting ring)
<b>Material</b>	Steel
<b>Surface</b>	electro galvanised

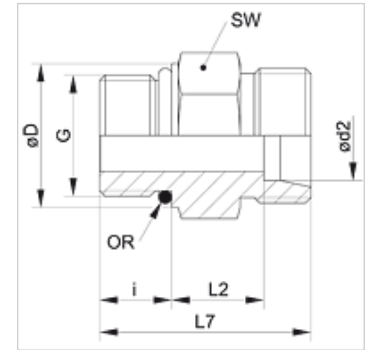

## Note

Information about fitting, installation, pressure loads and permissible operating temperatures can be found in the technical information for pipe fittings.

## Item

Identification	Series	Operating pressure	Ø d2 (mm)	G	Ø D (mm)	i (mm)	L2 (mm)	L7 (mm)	AF (mm)	OR
XVMO 04 LL	LL	PN 100	4	M 8 x 1	10,8	6,5	9,5	20,0	11	6.1 x 1.6
XVMO 04 LL 10	LL	PN 100	4	M 10 x 1	12,8	6,5	9,5	20,0	13	8.0 x 1.5
XVMO 06 LL	LL	PN 100	6	M 10 x 1	12,8	6,5	8,0	20,0	13	8.0 x 1.5
XVMO NW 04 HL	L	PN 250	6	M 10 x 1	14,0	8,5	8,5	24,0	14	8.0 x 1.5
XVMO NW 06 HL	L	PN 250	8	M 12 x 1.5	17,0	11,0	10,0	28,0	17	9.3 x 2.4
XVMO NW 08 HL	L	PN 250	10	M 14 x 1.5	19,0	11,0	11,0	29,0	19	11.3 x 2.4
XVMO NW 10 HL	L	PN 250	12	M 16 x 1.5	22,0	11,5	12,5	31,0	22	13.3 x 2.4
XVMO NW 10 HL 18	L	PN 315	12	M 18 x 1.5	24,0	12,0	12,5	31,5	24	15.3 x 2.4
XVMO NW 13 HL	L	PN 250	15	M 18 x 1.5	24,0	12,5	13,5	33,0	24	15.3 x 2.4
XVMO NW 13 HL 22	L	PN 315	15	M 22 x 1.5	27,0	13,0	15,0	35,0	27	19.3 x 2.4
XVMO NW 16 HL	L	PN 160	18	M 22 x 1.5	27,0	13,0	14,5	35,0	27	19.3 x 2.4
XVMO NW 20 HL	L	PN 160	22	M 26 x 1.5	31,0	16,0	17,5	41,0	41	23.3 x 2.4
XVMO NW 20 HL 27	L	PN 160	22	M 27 x 2	32,0	16,0	16,5	40,0	32	23.6 x 2.9
XVMO NW 25 HL	L	PN 100	28	M 33 x 2	41,0	16,0	17,5	41,0	41	29.5 x 3.0
XVMO NW 32 HL	L	PN 100	35	M 42 x 2	50,0	16,0	17,5	44,0	50	38.0 x 3.0
XVMO NW 40 HL	L	PN 160	42	M 48 x 2	55,0	17,5	19,0	47,5	55	44.6 x 3.0
XVMO NW 03 HS	S	PN 630	6	M 12 x 1.5	17,0	11,0	13,0	31,0	17	9.3 x 2.4
XVMO NW 04 HS	S	PN 630	8	M 14 x 1.5	19,0	11,0	15,0	33,0	19	11.3 x 2.4
XVMO NW 06 HS	S	PN 630	10	M 16 x 1.5	22,0	12,5	15,0	35,0	22	13.3 x 2.4
XVMO NW 08 HS	S	PN 630	12	M 18 x 1.5	24,0	14,0	17,0	38,5	24	15.3 x 2.4
XVMO NW 13 HS	S	PN 400	16	M 22 x 1.5	27,0	15,0	18,5	42,0	27	19.3 x 2.4
XVMO NW 16 HS	S	PN 400	20	M 27 x 2	32,0	18,5	20,5	49,5	32	23.5 x 3.0
XVMO NW 20 HS	S	PN 400	25	M 33 x 2	41,0	18,5	23,0	53,5	41	29.5 x 3.0
XVMO NW 25 HS	S	PN 250	30	M 42 x 2	50,0	19,0	23,5	56,0	50	38.0 x 3.0
XVMO NW 32 HS	S	PN 315	38	M 48 x 2	55,0	21,5	26,0	63,5	55	46.7 x 2.8

Series: LL = Very light L = Light S = Heavy – PN = Nominal pressure PB = Max. operating pressure – Ø d2 = External pipe diameter

## Product versions

VMO Screw-in fitting, Steel