

AFS 90 G (6000 PSI)

SAE screw-in flange, BSP, angle 90

Properties

Pressure series	6000 psi
Standard	SAE J 518 C ISO 6162
Construction	Angle 90°
Design	SAE screw-in flange
Mounting	Screw bore hole
Scope of supply	flange only
Material	S355J2G3 (ST52.3)
Surface	black oiled

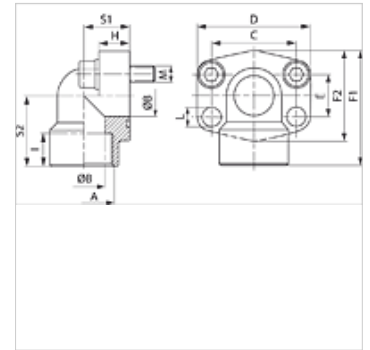
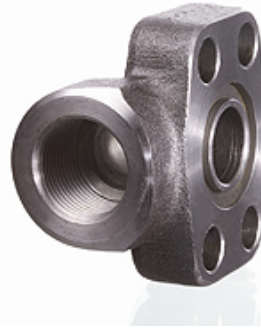

Note

The stated maximum working pressure relates to the flange. The actual working pressure is determined by the pipe (wall thickness) and the quality of the pipe.

Recommended screws are listed in the columns M (metr) and M (unc).

Item

Identification	PB 10.9 (bar)	Size	A	Ø B (mm)	C (mm)	E (mm)	F1 (mm)	I (mm)	S1 (mm)	S2 (mm)	L (mm)	M metr.	M unc
AFS 401/90 G 012	400	1/2"	G 1/2" -14	13	40,5	18,2	60	19	20	37	9,0	M 8 x 30	5/16" x 1.1/4"
AFS 401/90 G 038	400	1/2"	G 3/8" -19	13	40,5	18,2	60	19	20	37	9,0	M 8 x 30	5/16" x 1.1/4"
AFS 402/90 G	400	3/4"	G 3/4" -14	19	50,8	23,8	70	20	28	43	11,0	M 10 x 35	3/8" x 1.1/2"
AFS 403/90 G	400	1"	G 1" -11	25	57,2	27,8	85	22	34	51	13,0	M 12 x 45	7/16" x 1.3/4"
AFS 404/90 G	400	1.1/4"	G 1.1/4" -11	32	66,7	31,8	95	25	38	56	*1	M 14 x 50	1/2" x 1.3/4"
AFS 405/90 G	400	1.1/2"	G 1.1/2" -11	38	79,4	36,5	110	28	42	65	17,0	M 16 x 50	5/8" x 2"
AFS 406/90 G	400	2"	G 2" -11	51	96,8	44,5	132	33	45	75	21,0	M 20 x 70	-

PN = Nominal pressure PB = Max. operating pressure

*1) = 15.0 for metric screws; 13.5 for UNC screws

Product versions

AFS 90 G M (3000 / 6000 PSI)	SAE screw-in flange, BSP, angle 90°, with metric screw set and O-ring
AFS 90 G U (3000 / 6000 PSI)	SAE screw-in flange, BSP, angle 90°, with UNC screw set and O-ring