

AFS 90 G M (3000 / 6000 PSI)

SAE screw-in flange, BSP, angle 90°



Properties

Standard	SAE J 518 C ISO 6162
Construction	Angle 90°
Design	SAE screw-in flange
Mounting	Screw bore hole
Scope of supply	with metric screw set and O-ring
Material	S355J2G3 (ST52.3)
Surface	black oiled

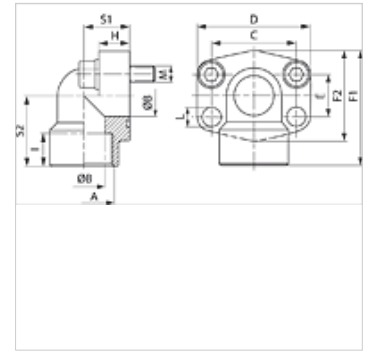

Note

The stated maximum working pressure relates to the flange. The actual working pressure is determined by the pipe (wall thickness) and the quality of the pipe.

Item

Identification	Pressure series	PB 10.9 (bar)	Size	A	Ø B	C	D	E	F1	F2	H	I	S1	S2	L	Screws
					(mm)	(mm)	(mm)	(mm)	(mm)	(mm)	(mm)	(mm)	(mm)	(mm)	(mm)	
AFS 80/90 G M	3000 PSI	350	1/2"	G 1/2" -14	13	38,1	54	17,5	60	48	16,0	19	20	37	9,0	(4 x) M 8 x 30
AFS 80/90 G M 038	3000 PSI	350	1/2"	G 3/8" -19	13	38,1	54	17,5	60	48	16,0	19	20	37	9,0	(4 x) M 8 x 30
AFS 100/90 G M	3000 PSI	350	3/4"	G 3/4" -14	19	47,6	65	22,2	63	52	18,0	19	24	38	11,0	(4 x) M 10 x 35
AFS 102/90 G M	3000 PSI	315	1"	G 1" -11	25	52,4	70	26,2	70	60	19,0	20	28	43	11,0	(4 x) M 10 x 35
AFS 104/90 G M	3000 PSI	250	1.1/4"	G 1.1/4" -11	32	58,7	79	30,2	85	73	21,0	22	34	51	11,5	(4 x) M 10 x 40
AFS 106/90 G M	3000 PSI	200	1.1/2"	G 1.1/2" -11	38	69,9	93	35,7	95	83	25,0	25	38	56	13,5	(4 x) M 12 x 45
AFS 108/90 G M	3000 PSI	200	2"	G 2" -11	51	77,8	110	42,9	110	94	25,0	28	42	65	13,5	(4 x) M 12 x 45
AFS 401/90 G M 012	6000 PSI	400	1/2"	G 1/2" -14	13	40,5	54	18,2	60	46	16,0	19	20	37	9,0	(4 x) M 8 x 30
AFS 401/90 G M 038	6000 PSI	400	1/2"	G 3/8" -19	13	40,5	54	18,2	60	46	16,0	19	20	37	9,0	(4 x) M 8 x 30
AFS 402/90 G M	6000 PSI	400	3/4"	G 3/4" -14	19	50,8	70	23,8	70	56	19,0	20	28	43	11,0	(4 x) M 10 x 35
AFS 403/90 G M	6000 PSI	400	1"	G 1" -11	25	57,2	79	27,8	85	72	21,0	22	34	51	13,0	(4 x) M 12 x 45
AFS 404/90 G M	6000 PSI	400	1.1/4"	G 1.1/4" -11	32	66,7	93	31,8	95	75	25,0	25	38	56	15,0	(4 x) M 14 x 50
AFS 405/90 G M	6000 PSI	400	1.1/2"	G 1.1/2" -11	38	79,4	110	36,5	110	94	25,0	28	42	65	17,0	(4 x) M 16 x 50
AFS 406/90 G M	6000 PSI	400	2"	G 2" -11	51	96,8	134	44,5	150	106	26,5	28	60	92	21,0	(4 x) M 20 x 110

PN = Nominal pressure PB = Max. operating pressure

Product versions

AFS 90 G (6000 PSI)	SAE screw-in flange, BSP, angle 90, flange only
AFS 90 G U (3000 / 6000 PSI)	SAE screw-in flange, BSP, angle 90°, with UNC screw set and O-ring