

# AFS 90 N (3000 PSI)

SAE screw-in flange, NPT, angle 90°

## Properties

<b>Pressure series</b>	3000 psi
<b>Standard</b>	SAE J 518 C ISO 6162
<b>Construction</b>	Angle 90°
<b>Design</b>	SAE screw-in flange
<b>Mounting</b>	Screw bore hole
<b>Scope of supply</b>	flange only
<b>Material</b>	S355J2G3 (ST52.3)
<b>Surface</b>	black oiled

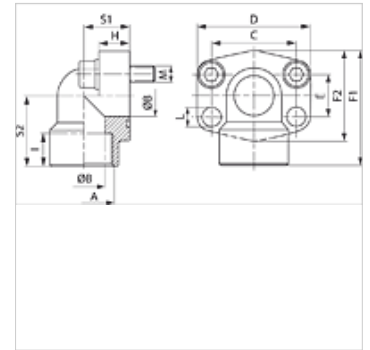
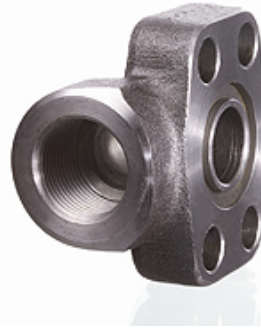

## Note

The stated maximum working pressure relates to the flange. The actual working pressure is determined by the pipe (wall thickness) and the quality of the pipe.

Recommended screws are listed in the columns M (metr) and M (unc).

## Item

Identification	PB 10.9 (bar)	Size	A	Ø B (mm)	C (mm)	E (mm)	F1 (mm)	H (mm)	I (mm)	S1 (mm)	S2 (mm)	L (mm)	M metr.	M unc
<b>AFS 80/90 N</b>	350	1/2"	NPT 1/2"	13	38,1	17,5	60	16	19	20	37	9,0	M 8 x 30	5/16" x 1.1/4"
<b>AFS 80/90 N 038</b>	350	1/2"	NPT 3/8" -18	13	38,1	17,5	60	16	19	20	37	9,0	M 8 x 30	5/16" x 1.1/4"
<b>AFS 100/90 N</b>	350	3/4"	NPT 3/4" -14	19	47,6	22,2	63	18	19	24	38	11,0	M 10 x 35	3/8" x 1.1/2"
<b>AFS 102/90 N</b>	315	1"	NPT 1"	25	52,4	26,2	70	19	20	28	43	11,0	M 10 x 35	5/16" x 1.1/4"
<b>AFS 104/90 N</b>	250	1.1/4"	NPT 1.1/4"	32	58,7	30,2	85	21	22	34	51	11,5	M 10 x 40	7/16" x 1.1/2"
<b>AFS 106/90 N</b>	200	1.1/2"	NPT 1.1/2"	38	69,9	35,7	95	25	25	38	56	13,5	M 12 x 45	1/2" x 1.3/4"
<b>AFS 108/90 N</b>	200	2"	NPT 2" -11.5	51	77,8	42,9	110	25	28	42	65	13,5	M 12 x 45	5/8" x 2"

PN = Nominal pressure PB = Max. operating pressure

## Product versions

<b>AFS 90 N M (3000 / 6000 PSI)</b>	SAE screw-in flange, NPT, angle 90°, with metric screw set and O-ring
<b>AFS 90 N U (3000 / 6000 PSI)</b>	SAE screw-in flange, NPT, angle 90°, with UNC screw set and O-ring