

# AFS 90 SRE U (3000 / 6000 PSI)

SAE welded on flange, angle 90°

**HANSA FLEX**

## Properties

<b>Standard</b>	SAE J 518 C ISO 6162
<b>Construction</b>	Angle 90°
<b>Design</b>	SAE welded on flange
<b>Mounting</b>	Screw bore hole
<b>Scope of supply</b>	with UNC screw set and O-ring
<b>Material</b>	S355J2G3 (ST52.3)
<b>Surface</b>	black oiled

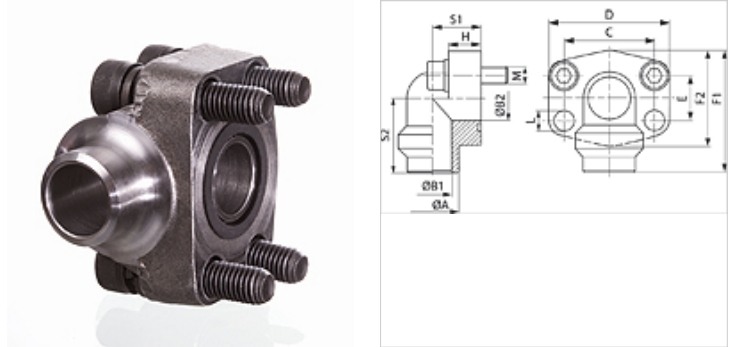

## Note

The stated maximum working pressure relates to the flange. The actual working pressure is determined by the pipe (wall thickness) and the quality of the pipe.

## Item

Identification	Pressure series	PB 10.9 (bar)	Size	Pipe	A	B1	B2	C	D	E	F1	F2	H	S1	S2	L	Screws
					(mm)	(mm)	(mm)	(mm)	(mm)	(mm)	(mm)	(mm)	(mm)	(mm)	(mm)	(mm)	
AFS 80/90 SRE 20 U	6000 PSI	250	1/2"	20 x 3	20	14	13	38,1	54,0	17,5	60	48	16	20	37	9,0	(4 x) UNC 5/16 x 1.1/4
AFS 80/90 SRE 22 U	6000 PSI	160	1/2"	22 x 2	22	18	13	38,1	54,0	17,5	60	48	16	20	37	9,0	(4 x) UNC 5/16 x 1.1/4
AFS 80/90 SRE 25 U	6000 PSI	250	1/2"	25 x 3	25	19	13	38,1	54,0	17,5	60	48	16	20	37	9,0	(4 x) UNC 5/16 x 1.1/4
AFS 80/90 SRE 28 U	6000 PSI	160	1/2"	28 x 3	28	22	13	38,1	54,0	17,5	60	48	16	20	37	9,0	(4 x) UNC 5/16 x 1.1/4
AFS 100/90 SRE 25 U	6000 PSI	250	3/4"	25 x 3	25	19	19	47,6	65,0	22,3	63	50	18	24	38	11,0	(4 x) UNC 3/8 x 1.1/2
AFS 100/90 SRE 28 U	6000 PSI	160	3/4"	28 x 3	28	22	19	47,6	65,0	22,3	63	50	18	24	38	11,0	(4 x) UNC 3/8 x 1.1/2
AFS 100/90 SRE 30 U	6000 PSI	250	3/4"	30 x 4	30	22	19	47,6	65,0	22,3	63	50	18	24	38	11,0	(4 x) UNC 3/8 x 1.1/2
AFS 100/90 SRE 35 U	6000 PSI	160	3/4"	35 x 4	35	27	19	47,6	65,0	22,3	63	50	18	24	38	11,0	(4 x) UNC 3/8 x 1.1/2
AFS 102/90 SRE 30 U	6000 PSI	250	1"	30 x 4	30	22	25	52,4	70,0	26,2	70	60	19	28	43	11,0	(4 x) UNC 3/8 x 1.1/2
AFS 102/90 SRE 35 U	6000 PSI	160	1"	35 x 4	35	27	25	52,4	70,0	26,2	70	60	19	28	43	11,0	(4 x) UNC 3/8 x 1.1/2
AFS 102/90 SRE 38 U	6000 PSI	250	1"	38 x 4	38	30	25	52,4	70,0	26,2	70	60	19	28	43	11,0	(4 x) UNC 3/8 x 1.1/2
AFS 102/90 SRE 42 U	6000 PSI	160	1"	42 x 3	42	36	25	52,4	70,0	26,2	70	60	19	28	43	11,0	(4 x) UNC 3/8 x 1.1/2
AFS 104/90 SRE 38 U	6000 PSI	250	1.1/4"	38 x 4	38	30	32	58,7	79,0	30,2	85	68	21	34	51	11,5	(4 x) UNC 7/16 x 1.1/2
AFS 104/90 SRE 42 U	6000 PSI	160	1.1/4"	42 x 3	42	36	32	58,7	79,0	30,2	85	68	21	34	51	11,5	(4 x) UNC 7/16 x 1.1/2
AFS 104/90 SRE 48 U	6000 PSI	160	1.1/4"	48.3 x 4.5	49	39	32	58,7	79,0	30,2	85	68	21	34	51	11,5	(4 x) UNC 7/16 x 1.1/2
AFS 106/90 SRE 38 U	6000 PSI	210	1.1/2"	38 x 4	38	30	38	69,9	93,0	35,7	95	78	25	38	56	13,5	(4 x) UNC 1/2 x 1.3/4
AFS 106/90 SRE 42 U	6000 PSI	160	1.1/2"	42 x 3	42	36	38	69,9	93,0	35,7	95	78	25	38	56	13,5	(4 x) UNC 1/2 x 1.3/4
AFS 106/90 SRE 48 U	6000 PSI	160	1.1/2"	48.3 x 4.5	49	39	38	69,9	93,0	35,7	95	78	25	38	56	13,5	(4 x) UNC 1/2 x 1.3/4
AFS 108/90 SRE 60 U	6000 PSI	200	2"	60.3 x 5.6	61	49	51	77,8	110,0	42,9	110	90	25	42	65	13,5	(4 x) UNC 1/2 x 1.3/4
AFS 108/90 SRE 76 U	6000 PSI	200	2"	76.1 x 7.1	77	62	51	77,8	110,0	42,9	110	90	25	42	65	13,5	(4 x) UNC 1/2 x 1.3/4
AFS 401/90 SRE 20 U	6000 PSI	315	1/2"	20 x 3	20	14	13	40,5	56,4	18,2	60	48	16	20	37	9,0	(4 x) UNC 5/16 x 1.1/4
AFS 401/90 SRE 25 U	6000 PSI	315	1/2"	25 x 4	25	17	13	40,5	56,4	18,2	60	48	16	20	37	9,0	(4 x) UNC 5/16 x 1.1/4
AFS 402/90 SRE 25 U	6000 PSI	315	3/4"	25 x 4	25	17	19	50,8	71,3	23,8	70	60	19	28	43	11,0	(4 x) UNC 3/8 x 1.1/2
AFS 402/90 SRE 30 U	6000 PSI	315	3/4"	30 x 4	30	22	19	50,8	71,3	23,8	70	60	19	28	43	11,0	(4 x) UNC 3/8 x 1.1/2
AFS 403/90 SRE 30 U	6000 PSI	315	1"	30 x 4	30	22	25	57,2	81,0	27,8	85	70	21	34	51	13,0	(4 x) UNC 7/16 x 1.1/2
AFS 403/90 SRE 38 U	6000 PSI	315	1"	38 x 5	38	28	25	57,2	81,0	27,8	85	70	21	34	51	13,0	(4 x) UNC 7/16 x 1.1/2
AFS 404/90 SRE 38 U	6000 PSI	315	1.1/4"	38 x 5	38	28	32	66,6	95,2	31,8	95	78	25	38	56	13,5	(4 x) UNC 1/2 x 1.3/4
AFS 404/90 SRE 48 U	6000 PSI	315	1.1/4"	48.3 x 8	49	32	32	66,6	95,2	31,8	95	78	25	38	56	13,5	(4 x) UNC 1/2 x 1.3/4
AFS 405/90 SRE 38 U	6000 PSI	315	1.1/2"	38 x 5	38	28	38	79,3	112,8	36,5	110	94	25	42	65	17,0	(4 x) UNC 5/8 x 2
AFS 405/90 SRE 48 U	6000 PSI	315	1.1/2"	48.3 x 8	49	32	38	79,3	112,8	36,5	110	94	25	42	65	17,0	(4 x) UNC 5/8 x 2
AFS 405/90 SRE 60 U	6000 PSI	315	1.1/2"	60.3 x 10	61	40	38	79,3	112,8	36,5	110	94	25	42	65	17,0	(4 x) UNC 5/8 x 2

PN = Nominal pressure PB = Max. operating pressure

## Product versions

<b>AFS 90 SRE (3000 PSI)</b>	SAE welded on flange, angle 90°, flange only
<b>AFS 90 SRE M (3000 / 6000 PSI)</b>	SAE welded on flange, angle 90°, with metric screw set and O-ring