

AFS N U (3000 / 6000 PSI)

SAE screw-in flange, NPT

HANSA FLEX

Properties

Standard	SAE J 518 C ISO 6162
Construction	straight
Design	SAE screw-in flange
Mounting	Screw bore hole
Scope of supply	with UNC screw set and O-ring
Material	S355J2G3 (ST52.3)
Surface	black oiled

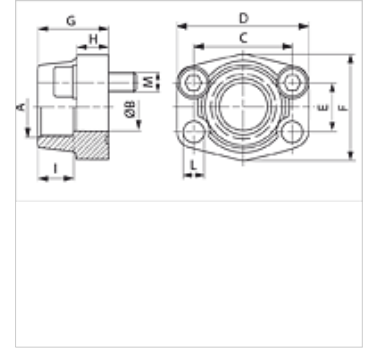

Note

The stated maximum working pressure relates to the flange. The actual working pressure is determined by the pipe (wall thickness) and the quality of the pipe.

Item

Identification	Pressure series	PB 10.9 (bar)	Size	A	Ø B (mm)	C (mm)	D (mm)	E (mm)	F (mm)	G (mm)	H (mm)	I (mm)	L (mm)	M unc
AFS 80 N 1/2 U	3000 PSI	350	1/2"	NPT 1/2"	13	38,1	54	17,5	46	36	16	19	9,0	5/16" x 1.1/4"
AFS 80 N 3/8 U	3000 PSI	350	1/2"	NPT 3/8" -18	13	38,1	54	17,5	46	36	16	19	9,0	5/16" x 1.1/4"
AFS 100 N 1/2 U	3000 PSI	350	3/4"	NPT 1/2"	13	47,6	65	22,2	50	36	18	19	11,0	3/8" x 1.1/2"
AFS 100 N 3/4 U	3000 PSI	350	3/4"	NPT 3/4" -14	19	47,6	65	22,2	50	36	18	19	11,0	3/8" x 1.1/2"
AFS 102 N 3/4 U	3000 PSI	315	1"	NPT 3/4" -14	19	52,4	70	26,2	55	35	21	19	11,0	3/8" x 1.1/2"
AFS 102 N 1 U	3000 PSI	315	1"	NPT 1"	25	52,4	70	26,2	55	38	18	22	11,0	3/8" x 1.1/2"
AFS 104 N 1 U	3000 PSI	250	1.1/4"	NPT 1"	25	58,7	81	30,2	65	42	25	22	11,5	7/16" x 1.1/2"
AFS 104 N 1 1/4 U	3000 PSI	250	1.1/4"	NPT 1.1/4"	32	58,7	79	30,2	68	41	21	22	11,5	7/16" x 1.1/2"
AFS 106 N 1 1/4 U	3000 PSI	200	1.1/2"	NPT 1.1/4"	32	69,9	95	35,7	78	45	27	24	13,5	1/2" x 1.3/4"
AFS 106 N 1 1/2 U	3000 PSI	200	1.1/2"	NPT 1.1/2"	38	69,9	93	35,7	78	45	25	24	13,5	1/2" x 1.3/4"
AFS 108 N 1 1/2 U	3000 PSI	200	2"	NPT 1.1/2"	38	77,8	102	42,9	90	45	25	26	13,5	1/2" x 1.3/4"
AFS 108 N 2 U	3000 PSI	200	2"	NPT 2" -11.5	51	77,8	102	42,9	90	45	25	30	13,5	1/2" x 1.3/4"
AFS 110 N 2 1/2 U	3000 PSI	160	2.1/2"	NPT 2.1/2" -11.5	63	88,9	114	50,8	105	50	25	30	13,5	1/2" x 1.3/4"
AFS 112 N U	3000 PSI	138	3"	NPT 3" -11.5	73	106,4	134	61,9	124	50	27	34	17,5	5/8" x 2"
AFS 114 N U	3000 PSI	35	3.1/2"	NPT 3.1/2" -11.5	89	120,7	152	69,9	136	48	27	34	17,5	5/8" x 2"
AFS 116 N U	3000 PSI	35	4"	NPT 4" -11.5	99	130,2	162	77,8	146	48	27	34	17,5	5/8" x 2"
AFS 401 N U	6000 PSI	400	1/2"	NPT 1/2"	13	40,5	54	18,2	46	36	16	19	9,0	5/16" x 1.1/4"
AFS 401 N 3/8 U	6000 PSI	400	1/2"	NPT 3/8" -18	13	40,5	54	18,2	46	36	16	19	9,0	5/16" x 1.1/4"
AFS 402 N U	6000 PSI	400	3/4"	NPT 3/4" -14	19	50,8	71	23,8	55	35	21	22	11,0	3/8" x 1.1/2"
AFS 402 N 1/2 U	6000 PSI	400	3/4"	NPT 1/2"	13	50,8	71	23,8	55	35	21	22	11,0	3/8" x 1.1/2"
AFS 403 N U	6000 PSI	400	1"	NPT 1"	25	57,2	81	27,8	65	42	25	24	13,0	7/16" x 1.3/4"
AFS 403 N 3/4 U	6000 PSI	400	1"	NPT 3/4" -14	19	57,2	81	27,8	65	42	25	24	13,0	7/16" x 1.3/4"
AFS 404 N U	6000 PSI	400	1.1/4"	NPT 1.1/4"	32	66,7	95	31,8	78	45	27	25	13,5	1/2" x 1.3/4"
AFS 404 N 1 U	6000 PSI	400	1.1/4"	NPT 1"	25	66,7	95	31,8	78	45	27	25	13,5	1/2" x 1.3/4"
AFS 405 N U	6000 PSI	400	1.1/2"	NPT 1.1/2"	38	79,4	112	36,5	94	50	30	28	17,0	5/8" x 2"
AFS 405 N 1 1/4 U	6000 PSI	400	1.1/2"	NPT 1.1/4"	32	79,4	112	36,5	94	50	30	28	17,0	5/8" x 2"
AFS 406 N U	6000 PSI	400	2"	NPT 2" -11.5	51	96,8	134	44,5	114	65	37	30	21,0	3/4" x 2.1/2"
AFS 406 N 1 1/2 U	6000 PSI	400	2"	NPT 1.1/2"	38	96,8	134	44,5	114	65	37	30	21,0	3/4" x 2.1/2"

PN = Nominal pressure PB = Max. operating pressure

Product versions

AFS N (3000 PSI)	SAE screw-in flange, NPT, flange only
AFS N M (3000 / 6000 PSI)	SAE screw-in flange, NPT, with metric screw set and O-ring