

# AFS S U (3000 / 6000 PSI)

SAE socket weld flange

**HANSA FLEX**

## Properties

<b>Standard</b>	SAE J 518 C ISO 6162
<b>Construction</b>	straight
<b>Design</b>	SAE socket weld flange
<b>Mounting</b>	Screw bore hole
<b>Scope of supply</b>	with UNC screw set and O-ring
<b>Material</b>	S355J2G3 (ST52.3)
<b>Surface</b>	black oiled

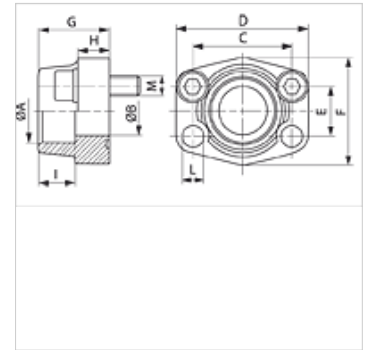

## Note

The stated maximum working pressure relates to the flange. The actual working pressure is determined by the pipe (wall thickness) and the quality of the pipe.

## Item

Identification	Pressure series	PB 10.9 (bar)	Size	A (mm)	Ø B (mm)	C (mm)	D (mm)	E (mm)	F (mm)	G (mm)	H (mm)	I (mm)	L (mm)	M unc
AFS 80 S U	3000 PSI	350	1/2"	21,6	13	38,1	54	17,5	46	36	16	19	9,0	5/16" x 1.1/4"
AFS 80 S U 3/8	3000 PSI	350	1/2"	17,5	13	38,1	54	17,5	46	36	16	19	9,0	5/16" x 1.1/4"
AFS 80 S U A20	3000 PSI	350	1/2"	20,3	13	38,1	54	17,5	46	36	16	19	9,0	5/16" x 1.1/4"
AFS 100 S U	3000 PSI	350	3/4"	27,2	19	47,6	65	22,2	50	36	18	19	11,0	3/8" x 1.1/2"
AFS 100 S U A25	3000 PSI	350	3/4"	25,3	19	47,6	65	22,2	50	36	18	19	11,0	3/8" x 1.1/2"
AFS 102 S U	3000 PSI	315	1"	34,0	25	52,4	70	26,2	55	38	18	19	11,0	3/8" x 1.1/2"
AFS 102 S U A30	3000 PSI	315	1"	30,3	25	52,4	70	26,2	55	38	18	19	11,0	3/8" x 1.1/2"
AFS 104 S U	3000 PSI	250	1.1/4"	42,8	32	58,7	79	30,2	68	41	21	22	11,5	7/16" x 1.1/2"
AFS 104 S U A38	3000 PSI	250	1.1/4"	38,3	32	58,7	79	30,2	68	41	21	22	11,5	7/16" x 1.1/2"
AFS 106 S U	3000 PSI	200	1.1/2"	48,6	38	69,9	93	35,7	78	45	25	24	13,5	1/2" x 1.3/4"
AFS 106 S U A50	3000 PSI	200	1.1/2"	50,5	38	69,9	93	35,7	78	45	25	24	13,5	1/2" x 1.3/4"
AFS 108 S U	3000 PSI	200	2"	61,0	51	77,8	102	42,9	90	45	25	26	13,5	1/2" x 1.3/4"
AFS 110 S U	3000 PSI	160	2.1/2"	76,6	63	88,9	114	50,8	105	50	25	30	13,5	1/2" x 1.3/4"
AFS 112 S U	3000 PSI	138	3"	90,5	73	106,4	134	61,9	124	50	27	34	17,5	5/8" x 2"
AFS 114 S U	3000 PSI	35	3.1/2"	103,0	89	120,7	152	69,9	136	48	27	34	17,5	5/8" x 2"
AFS 116 S U	3000 PSI	35	4"	115,1	99	130,2	162	77,8	146	48	27	34	17,5	5/8" x 2"
AFS 401 S U	6000 PSI	400	1/2"	21,6	13	40,5	54	18,2	46	36	16	19	9,0	5/16" x 1.1/4"
AFS 401 S U 3/8	6000 PSI	400	1/2"	17,5	13	40,5	54	18,2	46	36	16	19	9,0	5/16" x 1.1/4"
AFS 401 S U A20	6000 PSI	400	1/2"	20,3	13	40,5	54	18,2	46	36	16	19	9,0	5/16" x 1.1/4"
AFS 402 S U	6000 PSI	400	3/4"	27,2	19	50,8	71	23,8	55	35	21	22	11,0	3/8" x 1.1/2"
AFS 402 S U A25	6000 PSI	400	3/4"	25,3	19	50,8	71	23,8	55	35	21	22	11,0	3/8" x 1.1/2"
AFS 403 S U	6000 PSI	400	1"	34,0	25	57,2	81	27,8	65	42	25	22	13,0	7/16" x 1.3/4"
AFS 403 S U A30	6000 PSI	400	1"	30,3	25	57,2	81	27,8	65	42	25	22	13,0	7/16" x 1.3/4"
AFS 404 S U	6000 PSI	400	1.1/4"	42,8	32	66,7	95	31,8	78	45	27	25	13,5	1/2" x 1.3/4"
AFS 404 S U A38	6000 PSI	400	1.1/4"	38,3	32	66,7	95	31,8	78	45	27	25	13,5	1/2" x 1.3/4"
AFS 405 S U	6000 PSI	400	1.1/2"	48,6	38	79,4	112	36,5	94	50	30	28	17,5	5/8" x 2"
AFS 405 S U A50	6000 PSI	400	1.1/2"	50,5	38	79,4	112	36,5	94	50	30	28	17,5	5/8" x 2"
AFS 406 S U	6000 PSI	400	2"	61,0	51	96,8	134	44,5	114	65	37	24	21,0	3/4" x 2.1/2"

PN = Nominal pressure PB = Max. operating pressure

## Product versions

AFS S (3000 PSI)	SAE socket weld flange, flange only
AFS S M (3000 / 6000 PSI)	SAE socket weld flange, with metric screw set and O-ring