

DFS ST U (3000 / 6000 PSI)

SAE welded on flange connector, imperial

HANSA FLEX

Properties

Standard	SAE J 518 C ISO 6162
Construction	straight
Design	SAE welded on flange connector
Mounting	with UNC screw set
Scope of supply	with screw set and O-ring
Material	S355J2G3 (ST52.3)
Surface	black oiled

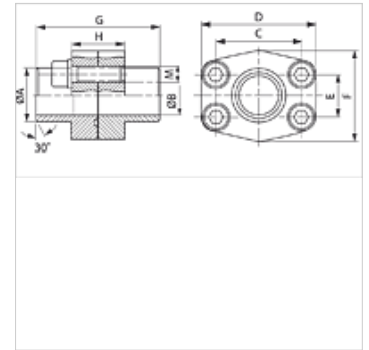

Note

The stated maximum working pressure relates to the flange. The actual working pressure is determined by the pipe (wall thickness) and the quality of the pipe.

Item

Identification	Pressure series	PB 10.9 (bar)	Size	A (mm)	Ø B (mm)	C (mm)	D (mm)	E (mm)	F (mm)	G (mm)	H (mm)	M unc
DFS 80 ST U	3000 PSI	350	1/2"	21,5	13	38,1	54	17,5	46	72	32	5/16" x 1.1/4"
DFS 80 ST U 038	3000 PSI	350	1/2"	17,5	13	38,1	54	17,5	46	72	32	5/16" x 1.1/4"
DFS 100 ST U	3000 PSI	350	3/4"	28,0	19	47,6	65	22,2	50	72	36	3/8" x 1.1/2"
DFS 102 ST U	3000 PSI	315	1"	34,0	25	52,4	70	26,2	55	76	36	3/8" x 1.1/2"
DFS 104 ST U	3000 PSI	250	1.1/4"	42,8	32	58,7	79	30,2	68	82	42	7/16" x 1.1/2"
DFS 106 ST U	3000 PSI	200	1.1/2"	48,6	38	69,9	93	35,7	78	88	50	1/2" x 1.3/4"
DFS 108 ST U	3000 PSI	200	2"	61,0	51	77,8	102	42,9	90	90	50	1/2" x 1.3/4"
DFS 110 ST U	3000 PSI	160	2.1/2"	77,0	63	88,9	114	50,8	105	100	50	1/2" x 1.3/4"
DFS 112 ST U	3000 PSI	138	3"	92,0	73	106,4	134	61,9	124	100	54	5/8" x 2"
DFS 114 ST U	3000 PSI	35	3.1/2"	103,0	89	120,7	152	69,9	136	96	54	5/8" x 2"
DFS 116 ST U	3000 PSI	35	4"	115,5	99	130,2	162	77,8	146	96	54	5/8" x 2"
DFS 401 ST U	6000 PSI	400	1/2"	21,5	13	40,5	54	18,2	46	72	32	5/16" x 1.1/4"
DFS 401 ST U 038	6000 PSI	400	1/2"	17,5	13	40,5	54	18,2	46	72	32	5/16" x 1.1/4"
DFS 402 ST U	6000 PSI	400	3/4"	28,0	19	50,8	71	23,8	55	70	42	3/8" x 1.1/2"
DFS 403 ST U	6000 PSI	400	1"	34,0	25	57,2	79	27,8	68	82	42	7/16" x 1.3/4"
DFS 404 ST U	6000 PSI	375	1.1/4"	42,8	32	66,7	95	31,8	78	88	48	1/2" x 1.3/4"
DFS 405 ST U	6000 PSI	250	1.1/2"	48,6	38	79,4	114	36,5	94	110	60	5/8" x 2"
DFS 406 ST U	6000 PSI	250	2"	61,0	51	96,8	134	44,5	114	130	74	3/4" x 2.1/2"

PN = Nominal pressure PB = Max. operating pressure

Product versions

DFS ST M (3000 / 6000 PSI) SAE welded on flange connector, imperial, with screw set and O-ring