

SFCE (3000 PSI)

SAE external thread flange

Properties

Pressure series	3000 psi
Standard	DIN 3901/3902
Construction	straight
Design	SAE external thread flange
Scope of supply	connecting piece only
Material	S355J2G3 (C22)
Surface	electro galvanised

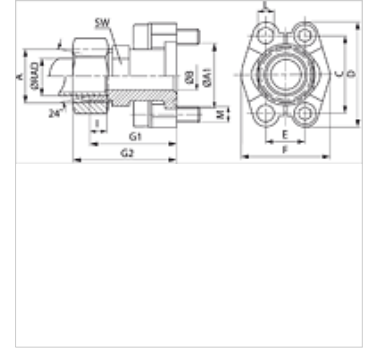

Note

In accordance with SAE J 518 C, the specified nominal pressure is defined by the flange or based on the pipe to be welded on. Recommended screws are listed in the columns M (metr) and M (unc).

Item

Identification	Series	Ø RAD (mm)	PB 10.9 (bar)	Size	A	A1 (mm)	Ø B (mm)	C (mm)	E (mm)	G1 (mm)	I (mm)	L (mm)	M metr.	M unc
SFCE 3001 L15	L	15	315	1/2"	M22x1,5	30,2	16 / 20	38,1	17,5	48,2	7,0	8,7	M 8 x 30	5/16" x 1.1/4"
SFCE 3002 L18	L	18	315	3/4"	M26x1,5	38,1	15 / 20	47,6	22,2	53,2	7,5	10,7	M 10 x 35	3/8" x 1.1/2"
SFCE 3002 L22	L	22	160	3/4"	M30x2	38,1	19	47,6	22,2	53,2	7,5	10,7	M 10 x 35	3/8" x 1.1/2"
SFCE 3002 L28	L	28	160	3/4"	M36x2	38,1	19	47,6	22,2	53,2	7,5	10,7	M 10 x 35	3/8" x 1.1/2"
SFCE 3003 L28	L	28	160	1"	M36x2	44,4	24	52,4	26,2	54,2	7,5	10,7	M 10 x 35	3/8" x 1.1/2"
SFCE 3004 L28	L	28	160	1.1/4"	M36x2	50,8	22	58,7	30,2	58,6	7,5	*1	*2	7/16" x 1.1/2"
SFCE 3004 L35	L	35	160	1.1/4"	M45x2	50,8	30 / 32	58,7	30,2	58,2	10,5	*1	*2	7/16" x 1.1/2"
SFCE 3005 L42	L	42	160	1.1/2"	M52x2	60,3	36	69,9	35,7	64,2	11,0	13,5	M 12 x 40	1/2" x 1.1/2"
SFCE 3001 S16	S	16	350	1/2"	M24x1,5	30,2	13	38,1	17,5	50,2	8,5	8,7	M 8 x 30	5/16" x 1.1/4"
SFCE 3002 S20	S	20	350	3/4"	M30x2	38,1	16 / 20	47,6	22,2	57,2	10,5	10,7	M 10 x 35	3/8" x 1.1/2"
SFCE 3002 S25	S	25	350	3/4"	M36x2	38,1	17	47,6	22,2	57,2	12,0	10,7	M 10 x 35	3/8" x 1.1/2"
SFCE 3003 S25	S	25	315	1"	M36x2	44,4	20	52,4	26,2	58,2	12,0	10,7	M 10 x 35	3/8" x 1.1/2"
SFCE 3003 S30	S	30	315	1"	M42x2	44,4	24	52,4	26,2	63,2	13,5	10,7	M 10 x 35	3/8" x 1.1/2"
SFCE 3004 S25	S	25	250	1.1/4"	M36x2	50,8	20 / 27	58,7	30,2	60,2	12,0	*1	*2	7/16" x 1.1/2"
SFCE 3004 S30	S	30	250	1.1/4"	M42x2	50,8	25 / 28	58,7	30,2	62,2	13,5	*1	*2	7/16" x 1.1/2"
SFCE 3004 S38	S	38	250	1.1/4"	M52x2	50,8	28	58,7	30,2	66,6	16,0	*1	*2	7/16" x 1.1/2"
SFCE 3005 S38	S	38	200	1.1/2"	M52x2	60,3	32	69,9	35,7	70,2	16,0	13,5	M 12 x 40	1/2" x 1.1/2"

Series: LL = Very light L = Light S = Heavy – PN = Nominal pressure PB = Max. operating pressure – Ø RAD = External pipe diameter

*1) = Choice of 10.5, 12.0 or 12.5 – *2) = Choice of M 10 x 30 or M 12 x 35

Product versions

SFCE M (3000 / 6000 PSI)	SAE external thread flange, with 2 flange halves, screw set, O-ring, nut and cutting ring
SFCE U (3000 / 6000 PSI)	SAE external thread flange, with 2 flange halves, screw set, O-ring, nut and cutting ring