

SFCE M (3000 / 6000 PSI)

SAE external thread flange

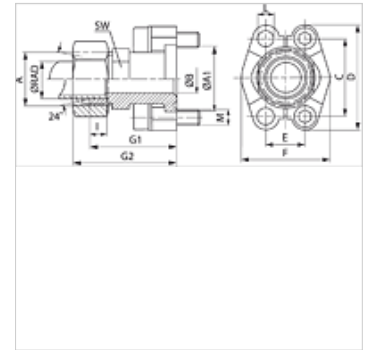

Properties	
Standard	DIN 3901/3902
Construction	straight
Design	SAE external thread flange
Scope of supply	with 2 flange halves, screw set, O-ring, nut and cutting ring
Material	S355J2G3 (C22)
Surface	electro galvanised



Note

In accordance with SAE J 518 C, the specified nominal pressure is defined by the flange or based on the pipe to be welded on.

Item

Identification	Pressure series	Series	Ø RAD (mm)	PB 10.9 (bar)	Size	A	A1 (mm)	Ø B (mm)	C (mm)	D (mm)	E (mm)	F (mm)	G1 (mm)	G2 (mm)	I (mm)	L (mm)	M metr.	AF (mm)
SFCE 3001 L 15 M	3000 PSI	L	15	315	1/2"	M22x1,5	30,2	16 / 20	38,1	54	17,5	45,6	48,2	56	7,0	8,7	M 8 x 30	24
SFCE 3001 L 22 M	3000 PSI	L	22	160	1/2"	M30x2	30,2	13	38,1	54	17,5	45,6	53,1	62	7,5	8,7	M 8 x 30	27
SFCE 3002 L 18 M	3000 PSI	L	18	315	3/4"	M26x1,5	38,1	15 / 20	47,6	65	22,2	51,8	53,2	62	7,5	10,7	M 10 x 35	30
SFCE 3002 L 22 M	3000 PSI	L	22	160	3/4"	M30x2	38,1	19	47,6	65	22,2	51,8	53,2	62	7,5	10,7	M 10 x 35	30
SFCE 3002 L 28 M	3000 PSI	L	28	160	3/4"	M36x2	38,1	19	47,6	65	22,2	51,8	53,2	62	7,5	10,7	M 10 x 35	30
SFCE 3003 L 28 M	3000 PSI	L	28	160	1"	M36x2	44,4	24	52,4	70	26,2	58,4	54,2	65	7,5	10,7	M 10 x 35	36
SFCE 3004 L 28 M	3000 PSI	L	28	160	1.1/4"	M36x2	50,8	22	58,7	79	30,2	72,6	58,6	67	7,5	*1	*2	36
SFCE 3004 L 35 M	3000 PSI	L	35	160	1.1/4"	M45x2	50,8	30 / 32	58,7	79	30,2	72,6	58,2	69	10,5	*1	*2	41
SFCE 3005 L 42 M	3000 PSI	L	42	160	1.1/2"	M52x2	60,3	36	69,9	94	35,7	82,2	64,2	76	11,0	13,5	M 12 x 40	46
SFCE 3001 S 16 M	3000 PSI	S	16	350	1/2"	M24x1,5	30,2	13	38,1	54	17,5	45,6	50,2	60	8,5	8,7	M 8 x 30	24
SFCE 3002 S 20 M	3000 PSI	S	20	350	3/4"	M30x2	38,1	16 / 20	47,6	65	22,2	51,8	57,2	68	10,5	10,7	M 10 x 35	30
SFCE 3002 S 25 M	3000 PSI	S	25	350	3/4"	M36x2	38,1	17	47,6	65	22,2	51,8	57,2	69	12,0	10,7	M 10 x 35	30
SFCE 3003 S 25 M	3000 PSI	S	25	315	1"	M36x2	44,4	20	52,4	70	26,2	58,4	58,2	70	12,0	10,7	M 10 x 35	36
SFCE 3003 S 30 M	3000 PSI	S	30	315	1"	M42x2	44,4	24	52,4	70	26,2	58,4	63,2	76	13,5	10,7	M 10 x 35	36
SFCE 3004 S 25 M	3000 PSI	S	25	250	1.1/4"	M36x2	50,8	20 / 27	58,7	79	30,2	72,6	60,2	72	12,0	*1	*2	41
SFCE 3004 S 30 M	3000 PSI	S	30	250	1.1/4"	M42x2	50,8	25 / 28	58,7	79	30,2	72,6	62,2	75	13,5	*1	*2	41
SFCE 3004 S 38 M	3000 PSI	S	38	250	1.1/4"	M52x2	50,8	28	58,7	79	30,2	72,6	66,6	81	16,0	*1	*2	46
SFCE 3005 S 38 M	3000 PSI	S	38	200	1.1/2"	M52x2	60,3	32	69,9	94	35,7	82,2	70,2	85	16,0	13,5	M 12 x 40	46
SFCE 6001 S 16 M	6000 PSI	S	16	400	1/2"	M24x1,5	31,7	12	40,5	56	18,2	47,2	53,2	63	8,5	8,5	M 8 x 30	24
SFCE 6002 S 16 M	6000 PSI	S	16	400	3/4"	M24x1,5	41,3	12	50,8	71	23,8	60,0	59,2	69	8,5	10,5	M 10 x 35	30
SFCE 6002 S 20 M	6000 PSI	S	20	400	3/4"	M30x2	41,3	16	50,8	71	23,8	60,0	61,2	72	10,5	10,5	M 10 x 35	30
SFCE 6002 S 25 M	6000 PSI	S	25	400	3/4"	M36x2	41,3	17	50,8	71	23,8	60,0	63,2	75	12,0	10,5	M 10 x 35	30
SFCE 6002 S 30 M	6000 PSI	S	30	400	3/4"	M42x2	41,3	18	50,8	71	23,8	60,0	64,0	77	13,5	10,5	M 10 x 35	36
SFCE 6003 S 25 M	6000 PSI	S	25	400	1"	M36x2	47,6	20	57,2	81	27,8	69,6	72,2	84	12,0	*3	M 12 x 45	41
SFCE 6003 S 30 M	6000 PSI	S	30	400	1"	M42x2	47,6	24	57,2	81	27,8	69,6	74,0	87	13,5	*3	M 12 x 45	41
SFCE 6004 S 30 M	6000 PSI	S	30	400	1.1/4"	M42x2	54,0	25 / 30	66,7	95	31,8	77,2	79,2	92	13,5	*4	M 14 x 50	41
SFCE 6004 S 38 M	6000 PSI	S	38	350	1.1/4"	M52x2	54,0	30	66,7	95	31,8	77,2	83,2	98	16,0	*4	M 14 x 50	46
SFCE 6005 S 38 M	6000 PSI	S	38	350	1.1/2"	M52x2	63,5	30	79,4	113	36,5	95,0	89,2	104	16,0	16,7	M 16 x 55	46

PN = Nominal pressure PB = Max. operating pressure - Ø = External pipe diameter - Series: LL = Very light L = Light S = Heavy

*1) = Choice of 10.5, 12.0 or 12.5 - *3) = Choice of 12.0 or 12.5 - *4) = Choice of 13.5 or 14.5 - *2) = Choice of M 10 x 30 or M 12 x 35

Product versions

SFCE (3000 PSI)	SAE external thread flange, connecting piece only
SFCE U (3000 / 6000 PSI)	SAE external thread flange, with 2 flange halves, screw set, O-ring, nut and cutting ring