

# SFS (3000 PSI)

SAE stub end

**HANSA FLEX**

## Properties

<b>Pressure series</b>	3000 psi
<b>Standard</b>	SAE J 518 C ISO 6162
<b>Construction</b>	straight
<b>Design</b>	SAE stub end
<b>Scope of supply</b>	short stub end only
<b>Material</b>	S355J2G3 (ST52.3)

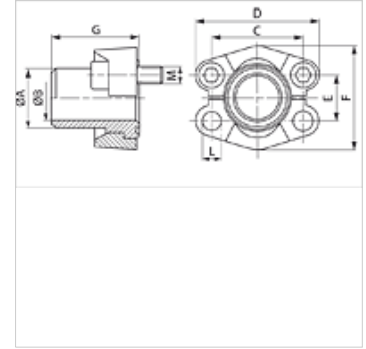
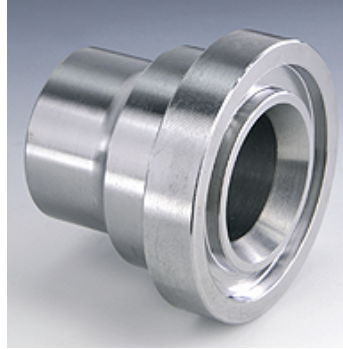

## Note

The stated maximum working pressure relates to the flange. The actual working pressure is determined by the pipe (wall thickness) and the quality of the pipe.

Recommended screws are listed in the columns M (metr) and M (unc).

## Item

Identification	PB 10.9 (bar)	Size	Pipe	A (mm)	Ø B (mm)	C (mm)	D (mm)	E (mm)	F (mm)	G (mm)	L (mm)	M metr.	M unc
SFS 3001 S 16	350	1/2"	16 x 2	16,0	12,0	38,1	54	17,5	45,6	41	8,5	M 8 x 30	5/16" x 1.1/4"
SFS 3001-21.3	350	1/2"	21.3 x 4.7	22,0	15,5	38,1	54	17,5	45,6	41	8,5	M 8 x 30	5/16" x 1.1/4"
SFS 3002-25	350	3/4"	25 x 3	27,0	18,9	47,6	65	22,2	51,8	50	10,5	M 10 x 30	3/8" x 1.1/4"
SFS 3002-26.9	350	3/4"	26.9 x 3.9	27,0	18,9	47,6	65	22,2	51,8	50	10,5	M 10 x 30	3/8" x 1.1/4"
SFS 3003-28	315	1"	28 x 3	28,0	22,0	52,4	70	26,2	58,4	50	10,5	M 10 x 35	3/8" x 1.1/4"
SFS 3003-30	315	1"	30 x 4	30,0	22,0	52,4	70	26,2	58,4	50	10,5	M 10 x 35	3/8" x 1.1/4"
SFS 3003-33.7	315	1"	33.7 x 4.5	35,0	24,7	52,4	70	26,2	58,4	50	10,5	M 10 x 35	3/8" x 1.1/4"
SFS 3003-38	315	1"	38 x 5	38,0	28,0	52,4	70	26,2	58,4	50	10,5	M 10 x 35	3/8" x 1.1/4"
SFS 3004-38	250	1.1/4"	38 x 5	38,0	28,0	58,7	79	30,2	72,6	55	*1	*2	7/16" x 1.1/2"
SFS 3004-42.4	250	1.1/4"	42.4 x 6.3	43,0	29,7	58,7	79	30,2	72,6	55	*1	*2	7/16" x 1.1/2"
SFS 3005-38	200	1.1/2"	38 x 4	38,0	30,0	69,9	94	35,7	82,2	57	13,5	M 12 x 35	1/2" x 1.1/2"
SFS 3005-42	200	1.1/2"	42 x 5	42,0	32,0	69,9	94	35,7	82,2	57	13,5	M 12 x 35	1/2" x 1.1/2"
SFS 3005-45	200	1.1/2"	45 x 5	45,0	35,0	69,9	94	35,7	82,2	57	13,5	M 12 x 35	1/2" x 1.1/2"
SFS 3005-48.3	200	1.1/2"	48.3 x 7.1	49,0	34,0	69,9	94	35,7	82,2	57	13,5	M 12 x 35	1/2" x 1.1/2"
SFS 3006-55	200	2"	55 x 5	55,0	45,0	77,8	102	42,9	96,4	57	13,5	M 12 x 35	1/2" x 1.1/2"
SFS 3006-60.3	200	2"	60.3 x 8	60,3	44,0	77,8	102	42,9	96,4	57	13,5	M 12 x 35	1/2" x 1.1/2"
SFS 3007-65	160	2.1/2"	65 x 6	65,0	53,0	88,9	114	50,8	108,2	58	13,5	M 12 x 40	1/2" x 1.3/4"
SFS 3007-70	160	2.1/2"	70 x 7.5	70,0	55,0	88,9	114	50,8	108,2	58	13,5	M 12 x 40	1/2" x 1.3/4"
SFS 3007-76.1	160	2.1/2"	76.1 x 7.1	74,0	62,0	88,9	114	50,8	108,2	58	13,5	M 12 x 40	1/2" x 1.3/4"
SFS 3008-80	138	3"	80 x 6	80,0	68,0	106,4	135	61,9	130,6	60	16,7	M 16 x 45	5/8" x 2"
SFS 3008-88.9	138	3"	88.9 x 8	90,0	73,0	106,4	135	61,9	130,6	60	16,7	M 16 x 45	5/8" x 2"
SFS 3009-100	35	3.1/2"	100 x 6	100,0	88,0	120,7	152	69,9	139,0	60	17,0	M 16 x 45	5/8" x 2"
SFS 3009-88.9	35	3.1/2"	88.9 x 8	90,0	73,0	120,7	152	69,9	139,0	60	17,0	M 16 x 45	5/8" x 2"
SFS 3010-110	35	4"	110 x 6	110,0	98,0	130,2	162	77,8	152,0	60	17,0	M 16 x 50	5/8" x 2"
SFS 3010-114.3	35	4"	114.3 x 8.8	115,0	96,7	130,2	162	77,8	152,0	60	17,0	M 16 x 50	5/8" x 2"
SFS 3011-133	35	5"	133 x 6.5	133,0	120,0	152,4	184	92,1	180,0	60	17,0	M 16 x 50	5/8" x 2"
SFS 3011-139.7	35	5"	139.7 x 10	140,0	120,0	152,4	184	92,1	180,0	60	17,0	M 16 x 50	5/8" x 2"

PN = Nominal pressure PB = Max. operating pressure

\*1) = Choice of 10.5 or 12.5 - \*2) = Choice of M 10 x 30 or M 12 x 35

## Product versions

**SFS M (3000 PSI)** SAE stub end, with 2 flange halves, screw set and O-ring

**SFS U (3000 PSI)** SAE stub end, with 2 flange halves, screw set and O-ring