

### Properties

<b>Design</b>	Pre-assembly sockets
<b>Material</b>	Hardened tool steel
<b>Surface</b>	phosphate treated

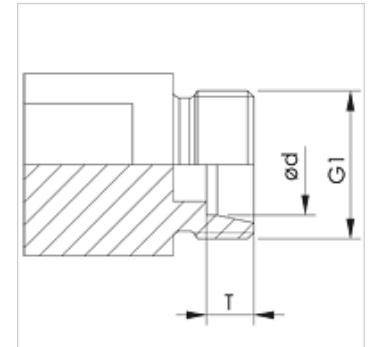

### Note

Information about fitting, installation, pressure loads and permissible operating temperatures can be found in the technical information for pipe fittings.

### Description

for manual fitting

### Item

Identification	Series	Ø d (mm)	G1	T +/- 0.05 (mm)
VOM 04 LL	LL	4	M 8 x 1	4,0
VOM 06 LL	LL	6	M 10 x 1	5,5
VOM 08 LL	LL	8	M 12 x 1	5,5
VOM 10 LL	LL	10	M 14 x 1	7,0
VOM 12 LL	LL	12	M 16 x 1	7,0
VOM NW 04 HL	L	6	M 12 x 1.5	7,0
VOM NW 06 HL	L	8	M 14 x 1.5	7,0
VOM NW 08 HL	L	10	M 16 x 1.5	7,0
VOM NW 10 HL	L	12	M 18 x 1.5	7,0
VOM NW 13 HL	L	15	M 22 x 1.5	7,0
VOM NW 16 HL	L	18	M 26 x 1.5	7,5
VOM NW 20 HL	L	22	M 30 x 2	7,5
VOM NW 25 HL	L	28	M 36 x 2	7,5
VOM NW 32 HL	L	35	M 45 x 2	10,5
VOM NW 40 HL	L	42	M 52 x 2	11,0
VOM NW 03 HS	S	6	M 14 x 1.5	7,0
VOM NW 04 HS	S	8	M 16 x 1.5	7,0
VOM NW 06 HS	S	10	M 18 x 1.5	7,5
VOM NW 08 HS	S	12	M 20 x 1.5	7,5
VOM NW 10 HS	S	14	M 22 x 1.5	8,0
VOM NW 13 HS	S	16	M 24 x 1.5	8,5
VOM NW 16 HS	S	20	M 30 x 2	10,5
VOM NW 20 HS	S	25	M 36 x 2	12,0
VOM NW 25 HS	S	30	M 42 x 2	13,5
VOM NW 32 HS	S	38	M 52 x 2	16,0

Series: LL = Very light L = Light S = Heavy