

GVR 90

Rotary fitting, angle 90°, friction bearing

HANSA FLEX

Properties

Connection 1	BSP external thread, cylindrical
Sealing form 1	Shape E
Connection 2	metric cylindrical outer thread
Sealing form 2	24° inner cone
Design	Rotary fitting (screw-in connector)
Construction type	Friction bearing
Construction	Angle 90°
Scope of supply	Socket (without union nut and cutting ring)
Material	Steel
Surface	electro galvanised

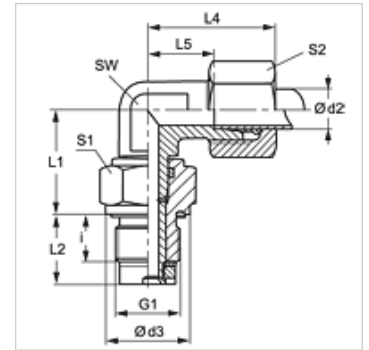

Note

Information about fitting, installation, pressure loads and permissible operating temperatures can be found in the technical information for pipe fittings.

Item

Identification	Series	Operating pressure	Ø d2 (mm)	G1	d3 (mm)	i (mm)	L1 (mm)	L2 (mm)	L4 (mm)	L5 (mm)	AF (mm)	S1	S2
GVR 90 NW 04 HL 1/4	L	PN 40	6	G 1/4" -19	19	12	20,0	18,0	27	12,0	12	19	14
GVR 90 NW 06 HL	L	PN 40	8	G 1/4" -19	19	12	21,0	18,0	29	14,0	12	19	17
GVR 90 NW 08 HL 3/8	L	PN 40	10	G 3/8" -19	22	12	26,0	18,0	30	15,0	14	24	19
GVR 90 NW 10 HL 1/2	L	PN 40	12	G 1/2" -14	27	14	27,0	21,0	32	17,0	17	27	22
GVR 90 NW 13 HL 3/4	L	PN 40	15	G 3/4" -14	32	16	33,0	24,0	36	21,0	19	32	27
GVR 90 NW 16 HL 1	L	PN 40	18	G 1" -11	40	18	37,5	27,5	40	23,5	27	41	32
GVR 90 NW 20 HL 1	L	PN 40	22	G 1" -11	40	18	39,5	27,5	44	27,5	27	41	36
GVR 90 NW 25 HL 1 1/4	L	PN 40	28	G 1.1/4" -11	50	20	44,0	31,0	47	30,5	36	50	41
GVR 90 NW 32 HL 1 1/2	L	PN 40	35	G 1.1/2" -11	55	22	54,0	35,0	56	34,5	41	55	50
GVR 90 NW 03 HS	S	PN 100	6	G 1/4" -19	19	12	21,0	18,0	31	16,0	12	19	17
GVR 90 NW 04 HS	S	PN 100	8	G 1/4" -19	19	12	22,0	18,0	32	17,0	14	19	19
GVR 90 NW 06 HS	S	PN 100	10	G 3/8" -19	22	12	27,0	18,0	34	17,5	17	24	22
GVR 90 NW 08 HS 1/2	S	PN 100	12	G 1/2" -14	27	14	28,0	21,0	38	21,5	17	27	24
GVR 90 NW 13 HS 3/4	S	PN 100	16	G 3/4" -14	32	16	34,0	24,0	43	24,5	24	32	30
GVR 90 NW 16 HS 1	S	PN 100	20	G 1" -11	40	18	39,5	27,5	48	26,5	27	41	36
GVR 90 NW 20 HS	S	PN 100	25	G 1" -11	40	18	42,5	27,5	54	30,0	36	41	46
GVR 90 NW 25 HS	S	PN 100	30	G 1.1/4" -11	50	20	48,0	31,0	62	35,5	41	50	50
GVR 90 NW 32 HS	S	PN 100	38	G 1.1/2" -11	55	22	55,0	35,0	72	41,0	50	55	60

Series: LL = Very light L = Light S = Heavy - PN = Nominal pressure PB = Max. operating pressure - Ø d2 = External pipe diameter