

Properties

Connection 1	BSP external thread, cylindrical
Sealing form 1	thread seal
Connection 2	metric cylindrical outer thread
Sealing form 2	24° inner cone
Design	Screw-in fitting
Construction	Angle 90°
Standard	DIN 2353 ISO 8434-1
Scope of supply	Socket with union nut and cutting ring
Material	Steel
Surface	electro galvanised

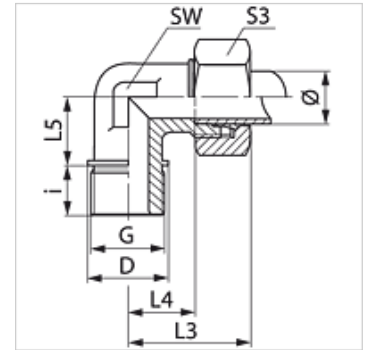

Note

Information about fitting, installation, pressure loads and permissible operating temperatures can be found in the technical information for pipe fittings.

Item

Identification	Series	Operating pressure	External pipe Ø (mm)	G	D (mm)	i (mm)	L3 (mm)	L4 (mm)	L5 (mm)	AF (mm)	S3
WR NW 10 HL 3/4	L	PN 315	12	G 3/4" -14	32	16	15	27,0	26	27	19
WR NW 20 HL	L	PN 160	22	G 3/4" -14	32	16	44	27,5	26	27	36
WR NW 25 HL	L	PN 160	28	G 1" -11	39	18	47	30,5	30	36	41
WR NW 32 HL	L	PN 160	35	G 1.1/4" -11	49	20	56	34,5	34	41	50
WR NW 40 HL	L	PN 160	42	G 1.1/2" -11	55	22	63	40,0	39	50	60
WR NW 16 HS	S	PN 400	20	G 3/4" -14	32	16	48	26,5	26	27	36
WR NW 20 HS	S	PN 400	25	G 1" -11	39	18	54	30,0	30	36	41
WR NW 25 HS	S	PN 250	30	G 1.1/4" -11	49	20	62	35,5	34	41	50
WR NW 32 HS	S	PN 250	38	G 1.1/2" -11	55	22	72	41,0	39	50	60

Series: LL = Very light L = Light S = Heavy – PN = Nominal pressure PB = Max. operating pressure – Ø = External pipe diameter

Product versions

WR MG	Screw-in fitting, angle 90°, Brass
WR VA	Screw-in fitting, angle 90°, Stainless steel
XWR	Screw-in fitting, angle 90°, Steel