

PN 02 AOL / PN 02 AOS

Swage nipple, DKOL / DKOS

HANSA FLEX

Properties

Application	Measuring equipment
Connection 1	metric nut thread
Sealing form 1	24° outer cone with O-ring
Short code	DKOL
Standard	ISO 8434-1
Material	Steel
Surface	electro galvanised

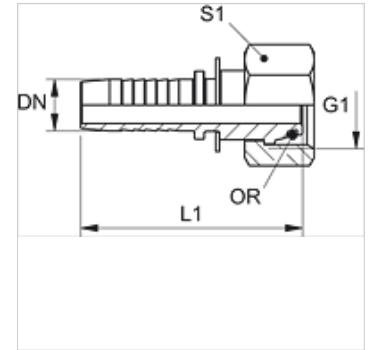

Note

Appropriate ferrule: PMH 102.

Item

Identification	DN	Size	Inches	Series	for external pipe Ø (mm)	G1	L1 (mm)	S1	OR
PN 02 AOL 04	2	1	5/64"	L	6	M 12 x 1.5	35,0	14	4.0 x 1.5
PN 02 AOL 06	2	1	5/64"	L	8	M 14 x 1.5	35,0	17	6.0 x 1.5
PN 02 AOL 08	2	1	5/64"	L	10	M 16 x 1.5	36,5	19	7.5 x 1.5
PN 02 AOL 10	2	1	5/64"	L	12	M 18 x 1.5	37,5	22	9.0 x 1.5
PN 02 AOS 03	2	1	5/64"	S	6	M 14 x 1.5	35,0	17	4.0 x 1.5
PN 02 AOS 04	2	1	5/64"	S	8	M 16 x 1.5	35,0	19	6.0 x 1.5
PN 02 AOS 06	2	1	5/64"	S	10	M 18 x 1.5	36,5	22	7.5 x 1.5
PN 02 AOS 08	2	1	5/64"	S	12	M 20 x 1.5	37,5	24	9.0 x 1.5

DN = Nominal diameter, nominal width – Series: LL = Very light L = Light S = Heavy