

# PN 02 AOL 45 / PN 02 AOS 45

Swage nipple, DKOL angle 45° / DKOS angle 45°

## Properties

<b>Application</b>	Measuring equipment
<b>Connection 1</b>	metric nut thread
<b>Sealing form 1</b>	24° outer cone with O-ring
<b>Short code</b>	DKOL
<b>Standard</b>	ISO 8434-1
<b>Material</b>	Steel
<b>Surface</b>	electro galvanised

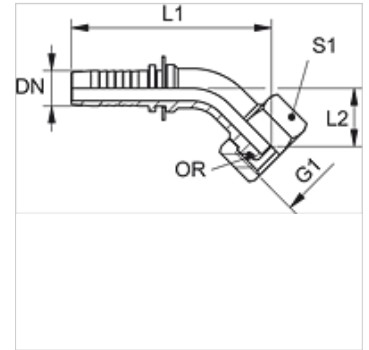

## Note

Appropriate ferrule: PMH 102.

## Item

Identification	DN	Size	Inches	Series	for external pipe Ø (mm)	G1	L1 (mm)	L2 (mm)	S1	OR
PN 02 AOL 04 45	2	1	5/64"	L	6	M 12 x 1.5	46,0	15,8	14	4.0 x 1.5
PN 02 AOL 06 45	2	1	5/64"	L	8	M 14 x 1.5	50,5	18,0	17	6.0 x 1.5
PN 02 AOL 08 45	2	1	5/64"	L	10	M 16 x 1.5	56,0	22,5	19	7.5 x 1.5
PN 02 AOS 03 45	2	1	5/64"	S	6	M 14 x 1.5	46,0	15,8	17	4.0 x 1.5
PN 02 AOS 04 45	2	1	5/64"	S	8	M 16 x 1.5	50,5	18,0	19	6.0 x 1.5
PN 02 AOS 06 45	2	1	5/64"	S	10	M 18 x 1.5	56,0	22,5	22	7.5 x 1.5

DN = Nominal diameter, nominal width – Series: LL = Very light L = Light S = Heavy