

# PN 02 HJ

## Swage nipple, AGJ

### Properties

<b>Application</b>	Measuring equipment
<b>Connection 1</b>	UN/UNF external threads
<b>Sealing form 1</b>	74° outer cone
<b>Short code</b>	AGJ
<b>Standard</b>	ISO 8434-2
<b>Material</b>	Steel
<b>Surface</b>	electro galvanised

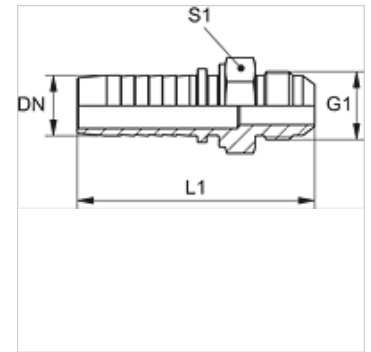

### Note

Appropriate ferrule: PMH 102.

### Item

Identification	DN	Size	Inches	G1	L1 (mm)	S1
PN 02 HJ 04	2	1	5/64"	3/8"-24 UNF	34,0	12
PN 02 HJ 06	2	1	5/64"	7/16"-20 UNF	34,5	12
PN 02 HJ 08	2	1	5/64"	1/2"-20 UNF	36,0	14

DN = Nominal diameter, nominal width