

PN 02 HN

Swage nipple, AGN

Properties

Application	Measuring equipment
Connection 1	NPT external threads
Sealing form 1	thread seal, additional 60° inner cone.
Short code	AGN
Material	Steel
Surface	electro galvanised

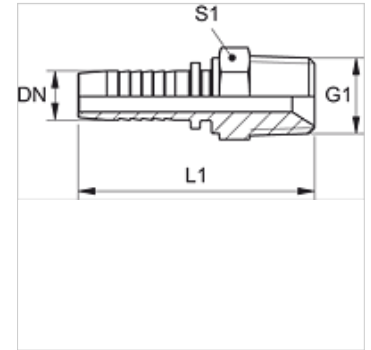

Note

Appropriate ferrule: PMH 102.

Item

Identification	DN	Size	Inches	G1	L1 (mm)	S1
PN 02 HN	2	1	5/64"	1/8" -27 NPT	30,0	12
PN 02 HN 06	2	1	5/64"	1/4" -18 NPT	35,5	17

DN = Nominal diameter, nominal width