

# PN ABK 90

Swage nipple, DKR Comp. angle 90°

**HANSA FLEX**

## Properties

<b>Application</b>	Swage nipple for HD 100 to HD 400, KP and TE hoses
<b>Connection 1</b>	BSP nut thread
<b>Sealing form 1</b>	60° outer cone
<b>Construction type</b>	Compact form
<b>Short code</b>	DKR
<b>Standard</b>	BS 5200
<b>Material</b>	Steel
<b>Surface</b>	electro galvanised

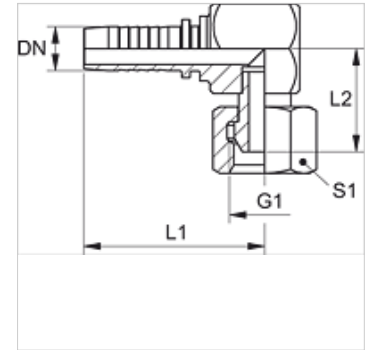

## Note

Choose the appropriate ferrule based on the hose type.

## Item

Identification	DN	Size	Inches	Operating pressure (bar)	G1	L1 (mm)	L2 (mm)	S1
PN 04 ABK 90	5	3	3/16"	350,0	G 1/8" -28	47,0	17,0	14
PN 06 ABK 90	6	4	1/4"	400,0	G 1/4" -19	50,0	20,0	19
PN 06 ABK 10 90	6	4	1/4"	400,0	G 3/8" -19	53,5	23,0	22
PN 08 ABK 10 90	8	5	5/16"	400,0	G 3/8" -19	54,0	23,0	22
PN 10 ABK 06 90	10	6	3/8"	400,0	G 1/4" -19	52,0	20,0	19
PN 10 ABK 90	10	6	3/8"	400,0	G 3/8" -19	55,5	23,0	22
PN 10 ABK 13 90	10	6	3/8"	350,0	G 1/2" -14	57,6	26,0	27
PN 13 ABK 90	12	8	1/2"	350,0	G 1/2" -14	59,6	26,0	27
PN 16 ABK 90	16	10	5/8"	350,0	G 5/8" -14	64,1	27,0	30
PN 20 ABK 90	19	12	3/4"	315,0	G 3/4" -14	74,8	32,0	32
PN 25 ABK 90	25	16	1"	250,0	G 1" -11	92,2	36,0	38