

PN ALI

Swage nipple, JIS

Properties

Application	Swage nipple for HD 100 to HD 400, KP and TE hoses
Connection 1	metric nut thread
Sealing form 1	60° inner cone
Standard	JIS 8363
suitable for	Komatsu
Material	Steel
Surface	electro galvanised

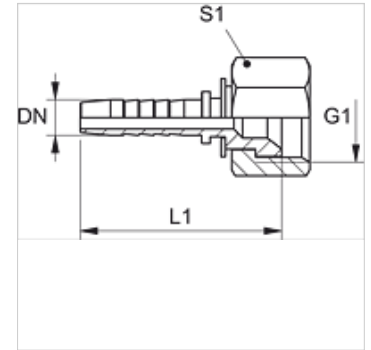

Note

Choose the appropriate ferrule based on the hose type.

Item								
Identification	DN	Size	Inches	Operating pressure (bar)	G1	L1 (mm)	S1	
PN 06 ALI	6	4	1/4"	345,0	M 14 x 1.5	44,0	19	
PN 06 ALI 08	6	4	1/4"	345,0	M 16 x 1.5	45,0	22	
PN 08 ALI	8	5	5/16"	345,0	M 16 x 1.5	44,0	22	
PN 10 ALI 06	10	6	3/8"	345,0	M 14 x 1.5	48,0	19	
PN 10 ALI 08	10	6	3/8"	345,0	M 16 x 1.5	47,5	22	
PN 10 ALI	10	6	3/8"	345,0	M 18 x 1.5	47,8	24	
PN 13 ALI	12	8	1/2"	345,0	M 22 x 1.5	50,5	27	
PN 13 ALI 16	12	8	1/2"	275,0	M 24 x 1.5	50,5	30	
PN 16 ALI	16	10	5/8"	275,0	M 24 x 1.5	55,0	30	
PN 20 ALI	19	12	3/4"	275,0	M 30 x 1.5	63,0	36	
PN 25 ALI	25	16	1"	205,0	M 33 x 1.5	71,6	41	
PN 32 ALI	31	20	1.1/4"	170,0	M 36 x 1.5	84,0	46	
PN 40 ALI	38	24	1.1/2"	170,0	M 42 x 1.5	90,5	50	