

PN ALI 45

Swage nipple, JIS angle 45°

Properties

Application	Swage nipple for HD 100 to HD 400, KP and TE hoses
Connection 1	metric nut thread
Sealing form 1	60° inner cone
Standard	JIS 8363
suitable for	Komatsu
Material	Steel
Surface	electro galvanised

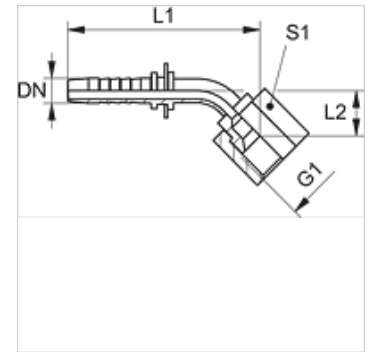

Note

Choose the appropriate ferrule based on the hose type.

Item

Identification	DN	Size	Inches	Operating pressure (bar)	G1	L1 (mm)	L2 (mm)	S1
PN 10 ALI 06 45	10	6	3/8"	345,0	M 14 x 1.5	77,0	18,0	19
PN 10 ALI 08 45	10	6	3/8"	345,0	M 16 x 1.5	90,0	25,0	22
PN 10 ALI 45	10	6	3/8"	345,0	M 18 x 1.5	91,0	25,0	22
PN 13 ALI 45	12	8	1/2"	345,0	M 22 x 1.5	99,0	29,0	27
PN 16 ALI 45	16	10	5/8"	275,0	M 24 x 1.5	-	-	-
PN 20 ALI 45	19	12	3/4"	275,0	M 30 x 1.5	124,0	34,0	36
PN 25 ALI 45	25	16	1"	205,0	M 33 x 1.5	146,0	41,0	41