

PN ALI 90

Swage nipple, JIS angle 90°

Properties

Application	Swage nipple for HD 100 to HD 400, KP and TE hoses
Connection 1	metric nut thread
Sealing form 1	60° inner cone
Standard	JIS 8363
suitable for	Komatsu
Material	Steel
Surface	electro galvanised

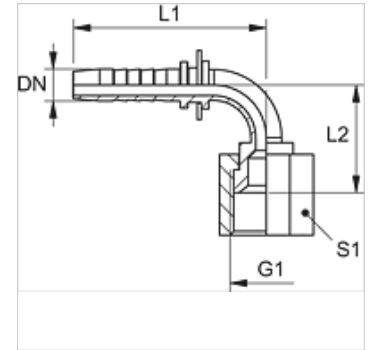

Note

Choose the appropriate ferrule based on the hose type.

Item

Identification	DN	Size	Inches	Operating pressure (bar)	G1	L1 (mm)	L2 (mm)	S1
PN 06 ALI 90	6	4	1/4"	345,0	M 14 x 1.5	63,0	31,0	17
PN 08 ALI 90	8	5	5/16"	345,0	M 16 x 1.5	70,0	42,0	19
PN 10 ALI 06 90	10	6	3/8"	345,0	M 14 x 1.5	64,0	31,0	19
PN 10 ALI 08 90	10	6	3/8"	345,0	M 16 x 1.5	72,0	42,0	22
PN 10 ALI 90	10	6	3/8"	345,0	M 18 x 1.5	73,0	42,0	22
PN 10 ALI 13 90	10	6	3/8"	345,0	M 22 x 1.5	89,0	58,0	27
PN 13 ALI 90	12	8	1/2"	345,0	M 22 x 1.5	88,0	58,0	27
PN 16 ALI 90	16	10	5/8"	275,0	M 24 x 1.5	92,0	58,0	30
PN 20 ALI 90	19	12	3/4"	275,0	M 30 x 1.5	109,0	67,0	36
PN 25 ALI 90	25	16	1"	205,0	M 33 x 1.5	118,0	70,0	41