

PN AOB

Swage nipple, DKOR

Properties

Application	Swage nipple for HD 100 to HD 400, KP and TE hoses
Connection 1	BSP nut thread
Sealing form 1	60° outer cone with O-ring
Short code	DKOR
Standard	ISO 8434-6 BS 5200
Material	Steel
Surface	electro galvanised

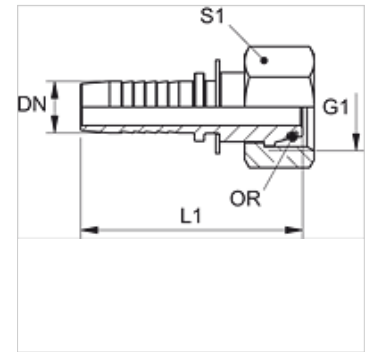

Note

Choose the appropriate ferrule based on the hose type.

Item

Identification	DN	Size	Inches	Operating pressure (bar)	G1	L1 (mm)	S1	OR
PN 06 AOB	6	4	1/4"	400,0	G 1/4" -19	44,5	19	6.0 x 1.0
PN 10 AOB	10	6	3/8"	400,0	G 3/8" -19	48,5	22	8.1 x 1.6
PN 13 AOB	12	8	1/2"	350,0	G 1/2" -14	51,0	27	12.1 x 1.6
PN 16 AOB	16	10	5/8"	350,0	G 5/8" -14	54,0	30	13.1 x 1.6
PN 20 AOB	19	12	3/4"	315,0	G 3/4" -14	63,5	32	17.1 x 1.6
PN 25 AOB	25	16	1"	250,0	G 1" -11	75,5	38	22.1 x 1.6
PN 25 AOB 32	25	16	1"	250,0	G 1.1/4" -11	78,0	50	29.1 x 1.6
PN 32 AOB	31	20	1.1/4"	250,0	G 1.1/4" -11	87,0	50	29.1 x 1.6
PN 32 AOB 40	31	20	1.1/4"	210,0	G 1.1/2" -11	88,5	55	35.1 x 1.6
PN 40 AOB	38	24	1.1/2"	210,0	G 1.1/2" -11	92,0	55	35.1 x 1.6
PN 40 AOB 50	38	24	1.1/2"	210,0	G 2" -11	97,0	70	48.1 x 1.6
PN 50 AOB	51	32	2"	210,0	G 2" -11	110,0	70	48.1 x 1.6