

PN AOB 90

Swage nipple, DKOR angle 90°

HANSA FLEX

Properties

Application	Swage nipple for HD 100 to HD 400, KP and TE hoses
Connection 1	BSP nut thread
Sealing form 1	60° outer cone with O-ring
Short code	DKOR
Standard	ISO 8434-6 BS 5200
Material	Steel
Surface	electro galvanised

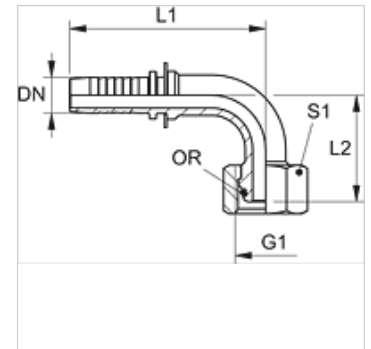

Note

Choose the appropriate ferrule based on the hose type.

Item

Identification	DN	Size	Inches	Operating pressure (bar)	G1	L1 (mm)	L2 (mm)	S1	OR
PN 06 AOB 90	6	4	1/4"	400,0	G 1/4" -19	55,0	27,0	19	6.0 x 1.0
PN 10 AOB 90	10	6	3/8"	400,0	G 3/8" -19	64,0	33,0	22	8.1 x 1.6
PN 13 AOB 90	12	8	1/2"	350,0	G 1/2" -14	72,5	38,0	27	12.1 x 1.6
PN 16 AOB 90	16	10	5/8"	350,0	G 5/8" -14	87,0	52,5	30	13.1 x 1.6
PN 20 AOB 90	19	12	3/4"	315,0	G 3/4" -14	99,0	58,0	32	17.1 x 1.6
PN 25 AOB 90	25	16	1"	250,0	G 1" -11	126,0	74,0	38	22.1 x 1.6
PN 25 AOB 32 90	25	16	1"	250,0	G 1.1/4" -11	127,0	69,5	50	29.1 x 1.6
PN 32 AOB 90	31	20	1.1/4"	250,0	G 1.1/4" -11	150,5	92,0	50	29.1 x 1.6
PN 32 AOB 40 90	31	20	1.1/4"	210,0	G 1.1/2" -11	150,5	91,5	55	35.1 x 1.6
PN 40 AOB 90	38	24	1.1/2"	210,0	G 1.1/2" -11	175,5	105,0	55	35.1 x 1.6
PN 40 AOB 50 90	38	24	1.1/4"	210,0	G 2" -11	175,5	105,0	70	48.1 x 1.6
PN 50 AOB 90	51	32	2"	210,0	G 2" -11	216,5	135,5	70	48.1 x 1.6