

PN AR

Swage nipple, DKR-Flat

Properties

Application	Swage nipple for HD 100 to HD 400, KP and TE hoses
Connection 1	BSP nut thread
Sealing form 1	flat sealing
Short code	DKR flat
Material	Steel
Surface	electro galvanised

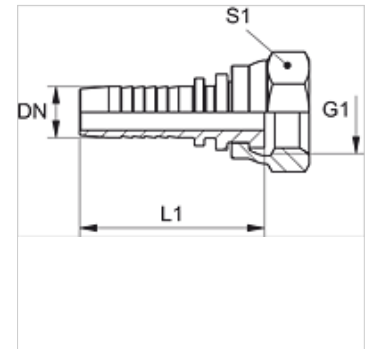

Note

Choose the appropriate ferrule based on the hose type.

LM = long nut

Item

Identification	DN	Size	Inches	Operating pressure (bar)	G1	L1 (mm)	S1
PN 06 AR 02	6	4	1/4"	350,0	G 1/8" -28	43,0	14
PN 06 AR	6	4	1/4"	350,0	G 1/4" -19	43,5	19
PN 06 AR 10	6	4	1/4"	350,0	G 3/8" -19	44,5	22
PN 08 AR 06	8	5	5/16"	350,0	G 1/4" -19	44,0	19
PN 08 AR 10	8	5	5/16"	350,0	G 3/8" -19	44,5	22
PN 08 AR 13	8	5	5/16"	315,0	G 1/2" -14	46,5	27
PN 10 AR 06	10	6	3/8"	350,0	G 1/4" -19	46,0	19
PN 10 AR	10	6	3/8"	350,0	G 3/8" -19	47,0	22
PN 10 AR 13	10	6	3/8"	315,0	G 1/2" -14	48,0	27
PN 10 AR 13 LM	10	6	3/8"	315,0	G 1/2" -14	48,0	27
PN 13 AR 10	12	8	1/2"	315,0	G 3/8" -19	48,5	22
PN 13 AR	12	8	1/2"	315,0	G 1/2" -14	50,0	27
PN 13 AR 16	12	8	1/2"	315,0	G 5/8" -14	49,5	30
PN 13 AR 20	12	8	1/2"	250,0	G 3/4" -14	49,5	32
PN 16 AR	16	10	5/8"	315,0	G 5/8" -14	55,0	30
PN 16 AR 20	16	10	5/8"	250,0	G 3/4" -14	54,0	32
PN 16 AR 25	16	10	5/8"	200,0	G 1" -11	56,5	41
PN 20 AR	19	12	3/4"	250,0	G 3/4" -14	61,5	32
PN 20 AR 25	19	12	3/4"	200,0	G 1" -11	63,0	41
PN 20 AR 32	19	12	3/4"	160,0	G 1.1/4" -11	66,5	50
PN 25 AR	25	16	1"	200,0	G 1" -11	72,0	38
PN 25 AR 32	25	16	1"	160,0	G 1.1/4" -11	74,5	50
PN 32 AR	31	20	1.1/4"	160,0	G 1.1/4" -11	84,5	50
PN 40 AR	38	24	1.1/2"	125,0	G 1.1/2" -11	88,0	55

Product versions

PN AR VA	Swage nipple, DKR-Flat, Stainless steel
----------	---