

PN ARI

Swage nipple, JIS

Properties

Application	Swage nipple for HD 100 to HD 400, KP and TE hoses
suitable for	Toyota
Connection 1	BSP nut thread
Sealing form 1	60° inner cone
Standard	JIS 8363
Material	Steel
Surface	electro galvanised

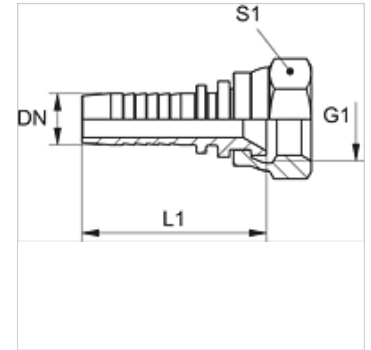

Note

Choose the appropriate ferrule based on the hose type.

Item								
Identification	DN	Size	Inches	Operating pressure (bar)	G1	L1 (mm)	S1	
PN 06 ARI 02	6	4	1/4"	-	G 1/8" -28	41,5	14	
PN 06 ARI	6	4	1/4"	-	G 1/4" -19	42,5	19	
PN 08 ARI 06	8	5	5/16"	-	G 1/4" -19	42,5	19	
PN 08 ARI 10	8	5	5/16"	-	G 3/8" -19	43,0	22	
PN 10 ARI	10	6	3/8"	-	G 3/8" -19	45,5	22	
PN 13 ARI	12	8	1/2"	345,0	G 1/2" -14	48,0	27	
PN 20 ARI	19	12	3/4"	275,0	G 3/4" -14	60,0	32	
PN 25 ARI	25	16	1"	205,0	G 1" -11	71,0	38	
PN 32 ARI	31	20	1.1/4"	170,0	G 1.1/4" -11	84,0	50	
PN 40 ARI	38	24	1.1/2"	105,0	G 1.1/2" -11	88,5	55	