

PN ASA 90

Swage nipple, SAE angle 90°

Properties

Application	Swage nipple for HD 100 to HD 400, KP and TE hoses
Connection 1	UN/UNF nut threads
Sealing form 1	45° inner cone
Material	Steel
Surface	electro galvanised

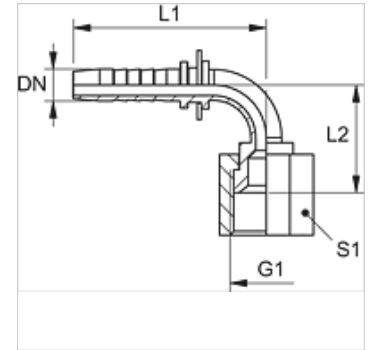

Note

Choose the appropriate ferrule based on the hose type.

Item

Identification	DN	Size	Inches	G1	L1 (mm)	L2 (mm)	S1
PN 10 ASA 90	10	6	3/8"	5/8"-18 UNF	72,0	40,0	22