

PN HB

Swage nipple, AGR

HANSA FLEX

Properties

| | |
|-----------------------|--|
| Application | Swage nipple for HD 100 to HD 400, KP and TE hoses |
| Connection 1 | BSP external thread, cylindrical |
| Sealing form 1 | 60° inner cone |
| Short code | AGR |
| Standard | ISO 8434-6 BS 5200 |
| Material | Steel |
| Surface | electro galvanised |

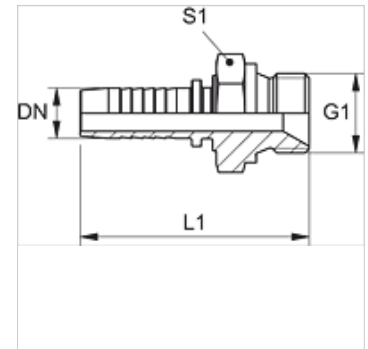

Note

Choose the appropriate ferrule based on the hose type.

Item

| Identification | DN | Size | Inches | Operating pressure (bar) | G1 | L1 (mm) | S1 |
|----------------|----|------|--------|-----------------------------|--------------|------------|----|
| PN 04 HB | 5 | 3 | 3/16" | 350,0 | G 1/8" -28 | 42,5 | 14 |
| PN 04 HB 06 | 5 | 3 | 3/16" | 350,0 | G 1/4" -19 | 46,0 | 19 |
| PN 06 HB 02 | 6 | 4 | 1/4" | 350,0 | G 1/8" -28 | 48,5 | 14 |
| PN 06 HB | 6 | 4 | 1/4" | 400,0 | G 1/4" -19 | 52,0 | 19 |
| PN 06 HB 10 | 6 | 4 | 1/4" | 400,0 | G 3/8" -19 | 54,0 | 22 |
| PN 06 HB 13 | 6 | 4 | 1/4" | 350,0 | G 1/2" -14 | 57,5 | 27 |
| PN 08 HB 06 | 8 | 5 | 5/16" | 400,0 | G 1/4" -19 | 52,0 | 19 |
| PN 08 HB 10 | 8 | 5 | 5/16" | 400,0 | G 3/8" -19 | 54,0 | 22 |
| PN 08 HB 13 | 8 | 5 | 5/16" | 350,0 | G 1/2" -14 | 57,5 | 27 |
| PN 10 HB 02 | 10 | 6 | 3/8" | 350,0 | G 1/8" -28 | 50,0 | 17 |
| PN 10 HB 06 | 10 | 6 | 3/8" | 400,0 | G 1/4" -19 | 53,5 | 19 |
| PN 10 HB | 10 | 6 | 3/8" | 400,0 | G 3/8" -19 | 55,5 | 22 |
| PN 10 HB 13 | 10 | 6 | 3/8" | 350,0 | G 1/2" -14 | 59,5 | 27 |
| PN 13 HB 10 | 12 | 8 | 1/2" | 350,0 | G 3/8" -19 | 56,5 | 22 |
| PN 13 HB | 12 | 8 | 1/2" | 350,0 | G 1/2" -14 | 60,5 | 27 |
| PN 13 HB 16 | 12 | 8 | 1/2" | 350,0 | G 5/8" -14 | 62,5 | 30 |
| PN 13 HB 20 | 12 | 8 | 1/2" | 250,0 | G 3/4" -14 | 62,5 | 32 |
| PN 16 HB 13 | 16 | 10 | 5/8" | 350,0 | G 1/2" -14 | 65,0 | 27 |
| PN 16 HB | 16 | 10 | 5/8" | 35,0 | G 5/8" -14 | 67,0 | 30 |
| PN 16 HB 20 | 16 | 10 | 5/8" | 315,0 | G 3/4" -14 | 67,0 | 32 |
| PN 20 HB | 19 | 12 | 3/4" | 315,0 | G 3/4" -14 | 73,5 | 32 |
| PN 20 HB 25 | 19 | 12 | 3/4" | 250,0 | G 1" -11 | 78,5 | 41 |
| PN 25 HB | 25 | 16 | 1" | 250,0 | G 1" -11 | 86,5 | 41 |
| PN 25 HB 32 | 25 | 16 | 1" | 250,0 | G 1.1/4" -11 | 87,5 | 50 |
| PN 32 HB | 31 | 20 | 1.1/4" | 250,0 | G 1.1/4" -11 | 97,0 | 50 |
| PN 32 HB 40 | 31 | 20 | 1.1/4" | 210,0 | G 1.1/2" -11 | 100,0 | 55 |
| PN 40 HB 32 | 38 | 24 | 1.1/2" | 210,0 | G 1.1/4" -11 | 100,5 | 50 |
| PN 40 HB | 38 | 24 | 1.1/2" | 210,0 | G 1.1/2" -11 | 103,5 | 55 |
| PN 40 HB 50 | 38 | 24 | 1.1/2" | 210,0 | G 2" -11 | 109,0 | 70 |
| PN 50 HB | 51 | 32 | 2" | 210,0 | G 2" -11 | 124,5 | 70 |

Product versions

PN HB VA Swage nipple, AGR, Stainless steel