

PN HM

Swage nipple, AGM-Flat

Properties

Application	Swage nipple for HD 100 to HD 400, KP and TE hoses
Connection 1	metric cylindrical outer thread
Sealing form 1	flat sealing
Short code	AGM-Flat
Standard	DIN 3852
Material	Steel
Surface	electro galvanised

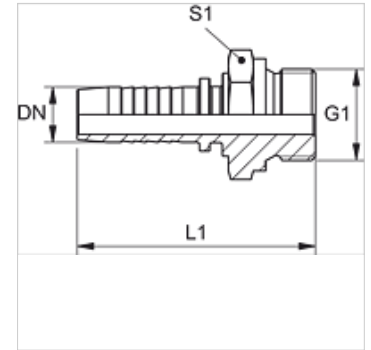

Note

Choose the appropriate ferrule based on the hose type.

Item						
Identification	DN	Size	Inches	G1	L1 (mm)	S1
PN 06 HM 02	6	4	1/4"	M 10 x 1	50,5	14
PN 06 HM	6	4	1/4"	M 14 x 1.5	53,0	19
PN 08 HM	8	5	5/16"	M 16 x 1.5	54,5	22
PN 08 HM 10	8	5	5/16"	M 18 x 1.5	56,0	24
PN 10 HM 08	10	6	3/8"	M 16 x 1.5	55,5	22
PN 10 HM	10	6	3/8"	M 18 x 1.5	57,0	24
PN 13 HM	12	8	1/2"	M 22 x 1.5	59,5	27
PN 16 HM	16	10	5/8"	M 26 x 1.5	65,0	32
PN 20 HM	19	12	3/4"	M 30 x 1.5	74,5	36
PN 25 HM	25	16	1"	M 38 x 1.5	83,0	46
PN 32 HM	31	20	1.1/4"	M 45 x 1.5	95,0	55
PN 40 HM	38	24	1.1/2"	M 52 x 1.5	101,0	60