

# PN SF9 45

Swage nipple, SFS-CAT angle 45°

## Properties

<b>Application</b>	Swage nipple for HD 100 to HD 400, KP and TE hoses
<b>Connection 1</b>	SAE flange connection 6000 PSI
<b>Sealing form 1</b>	flat seal with SF O-ring
<b>Short code</b>	SFS-CAT
<b>suitable for</b>	Caterpillar
<b>Material</b>	Steel
<b>Surface</b>	electro galvanised

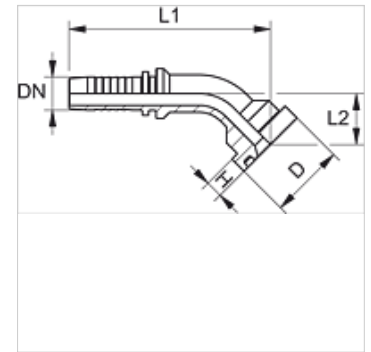

## Note

Choose the appropriate ferrule based on the hose type.

## Item

Identification	DN	Size	Inches	Flange size	Operating pressure (bar)	D (mm)	H (mm)	L1 (mm)	L2 (mm)
PN 20 SF9 45	19	12	3/4"	3/4"	420,0	41,3	14,6	114,0	34,5
PN 20 SF9 25 45	19	12	3/4"	1"	420,0	47,6	14,6	118,0	38,5
PN 25 SF9 45	25	16	1"	1"	420,0	47,6	14,6	140,5	38,5
PN 25 SF9 32 45	25	16	1"	1.1/4"	420,0	54,0	14,6	145,0	43,0
PN 32 SF9 45	31	20	1.1/4"	1.1/4"	420,0	54,0	14,6	167,0	47,0
PN 32 SF9 40 45	31	20	1.1/4"	1.1/2"	420,0	63,5	14,6	171,0	51,5
PN 40 SF9 45	38	24	1.1/2"	1.1/2"	420,0	63,5	14,6	191,0	53,0