

PN WAP

Swage nipple, WAP

Properties

Application	for HF/HW 100 and HF/HW 200 hoses
Connection 1	metric nut thread
Sealing form 1	Outer cone with O-ring
suitable for	WAP high pressure cleaners
Material	Steel
Surface	electro galvanised

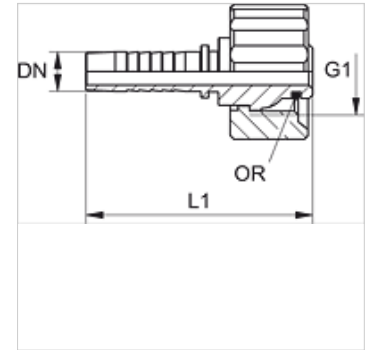

Note

Choose the appropriate ferrule based on the hose type.

Item					
Identification	DN	Size	Inches	G1	OR
PN 08 WAP	8	5	5/16"	M 21 x 1.5	10.0 x 2.0
PN 10 WAP	10	6	3/8"	M 21 x 1.5	10.0 x 2.0