

Properties

Connection 1	Pipe sockets
Sealing form 1	Cutting ring connection
Short code	BEL
Standard	ISO 8434-1
Material	Steel
Surface	electro galvanised

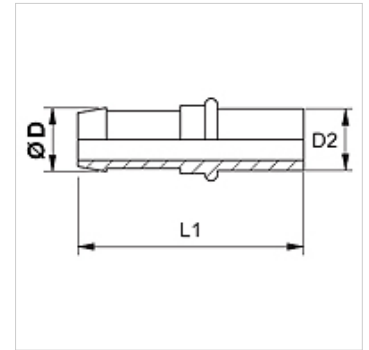

Note

Do not use for new designs; we recommend: SIN...AFL.
 Final cutting ring assembly must be carried out in the hardened pre-assembly socket (VOM...).
 Choose the appropriate ferrule based on the hose type.

Item

Identification	DN	Size	Inches	Ø D (mm)	Ø d2 (mm)	L1 (mm)
SIN 03 FL 02	3	2	1/8"	-	4	54
SIN 04 FL 03	4	3	3/16"	6,0	5	48
SIN 04 FL	4	3	3/16"	6,0	6	54
SIN 06 FL	6	4	1/4"	8,0	8	51
SIN 08 FL	8	5	5/16"	10,0	10	51
SIN 10 FL	10	6	3/8"	12,0	12	57
SIN 13 FL	12	8	1/2"	15,0	15	61
SIN 16 FL	16	10	5/8"	18,0	18	76

Additional elements

VOM	Pre-assembly sockets
-----	----------------------