

SIN FL 45

Swage nipple, BEL angle 45°

HANSA FLEX

Properties

Connection 1 Pipe sockets

Sealing form 1 Cutting ring connection

Short code BEL

Standard ISO 8434-1

Material Steel

Surface electro galvanised

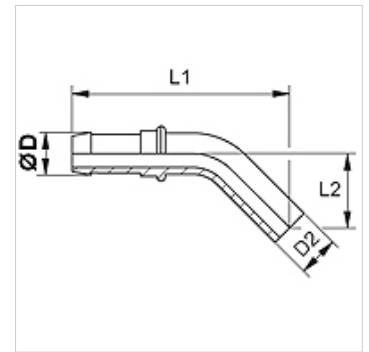

Note

Final cutting ring assembly must be carried out in the hardened pre-assembly socket (VOM...).

Choose the appropriate ferrule based on the hose type.

Item

Identification	DN	Size	Inches	Ø D (mm)	Ø d2 (mm)	L1 (mm)	L2 (mm)
SIN 04 FL 45	4	3	3/16"	6,0	6	53	15
SIN 06 FL 45	6	4	1/4"	8,0	8	62	23
SIN 08 FL 45	8	5	5/16"	10,0	10	79	25
SIN 10 FL 45	10	6	3/8"	12,0	12	88	32
SIN 13 FL 45	12	8	1/2"	15,0	15	-	-

Additional elements

VOM Pre-assembly sockets