

# JG 15 WB / JG 22 WB

Angle 90° to wall mounting

**HANSA FLEX**

## Properties

<b>Application</b>	Pneumatic, vacuum and food applications
<b>Connection 1</b>	BSP cylindrical internal threads
<b>Sealing form 1</b>	for screw-in pins with shapes A, B and if necessary E
<b>Connection 2</b>	Plug in sleeve
<b>Construction</b>	Angle 90°
<b>Design</b>	Angle connector with wall connecting plate
<b>Media</b>	Air fluid media inert gases, e.g., N <sub>2</sub> /CO <sub>2</sub>
<b>Material</b>	Brass

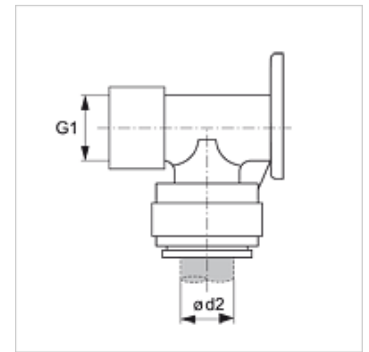

## Item

Identification	Ø d2 (mm)	G1
JG 15 WB	15	G 1/2" -14
JG 22 WB	22	G 3/4" -14

## Accessories

JG 18 S	Locking ring for connectors
JG 19 E	Cap for connectors