

# 3 BKR L

3-way ball valve in block design

## Properties

<b>Connection 1 - 3</b>	BSP cylindrical internal threads
<b>Sealing form 1 - 3</b>	for screw-in pins with shapes A, B and if necessary E.
<b>Bore</b>	L shaped
<b>Contact travel</b>	0°; 90°
<b>Temp. min.</b>	-10 °C
<b>Temp. max.</b>	80 °C
<b>Material</b>	Steel housing, ball and operating shaft POM ball seal NBR O-ring
<b>Surface</b>	burnished

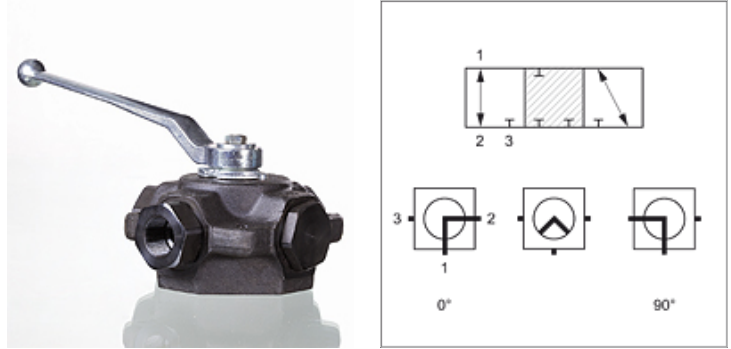

## Note

Please refer to the operating instructions for ball valves.  
Note the permissible pressure limits for the connecting elements.

## Item

Identification	DN*	Connecting thread	Overlap	LW (mm)	Operating pressure	AF (mm)	SF*
<b>3 BKR 04 L</b>	4	G 1/8" -28	positive (closed)	5,0	PN 500	12	1,5
<b>3 BKR 06 L</b>	6	G 1/4" -19	positive (closed)	6,0	PN 500	12	1,5
<b>3 BKR 10 L</b>	10	G 3/8" -19	positive (closed)	9,0	PN 500	14	1,5
<b>3 BKR 13 L</b>	12	G 1/2" -14	positive (closed)	11,5	PN 400	14	1,5
<b>3 BKR 20 L</b>	19	G 3/4" -14	positive (closed)	18,0	PN 400	17	1,5
<b>3 BKR 25 L</b>	25	G 1" -11	positive (closed)	22,0	PN 350	17	1,5
<b>3 BKR 32 L</b>	31	G 1.1/4" -11	positive (closed)	22,0	PN 350	17	1,5
<b>3 BKR 40 L</b>	38	G 1.1/2" -11	positive (closed)	22,0	PN 63	22	1,5

DN = Nominal diameter, nominal width – LW = Clearance – PN = Nominal pressure – PB = Max. operating pressure – AF = Width across flats – SF = Safety factor

## Spare parts

<b>BK ANSCHLAG</b>	Stop washers for ball valve
<b>BK GEKR GRIFF SW</b>	Handle (offset) for ball valve