

HK MPF

Return flow filter complete

Properties

Design	with bypass valve 1.75 bar, without clogging indicator A10: with inorganic filter (10 µm), absolute filtration P10: paper filter (10 µm), nominal filtration
Temp. min.	-25 °C
Temp. max.	110 °C
Material	Gasket: NBR
Operating pressure	max. 8 bar

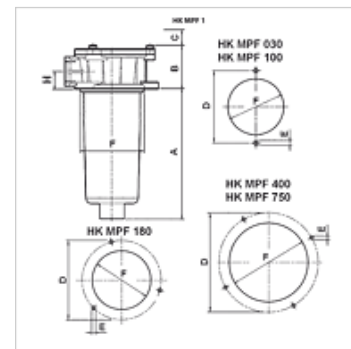

Note

Dimension "C": clearance required for changing the filter element

Description

Return flow filter for fitting into the tank cap; dimensions for drilling pattern see graphic.

Pressure differential for filter element paper (P) max. 3 bar

Pressure differential for inorganic filter element (A) max. 10 bar

Connector for clogging indicator G 1/8" closed with bolt

Design (Qmax.) for medium ISO VG 46
at 50°C (30 mm²/s) at Δp_{tot} = 0.4 bar

Ordering information

Filter materials for other types of oil, viscosities or temperatures available on request

Item

Identification	Filter mesh size (µm)	Filter area (m ²)	Line connection	Ø d (mm)	Q max. (L/min)	A (mm)	B (mm)	C (mm)	D (mm)	E (mm)	F (mm)	H (mm)	L (mm)	L1 (mm)	L2 (mm)	L3 (mm)	L6 (mm)	Weight (kg)
HK MPF 030 1 G1 A10	10,0	335	G 1/2"	66,0	24	86	56,0	100	90	7,0	66,0	22,0	100,0	86,0	56,0	22,0	90,0	0,36
HK MPF 030 1 G1 P10	10,0	410	G 1/2"	-	60	86	56,0	100	90	7,0	66,0	22,0	-	-	-	-	-	0,36
HK MPF 100 1 G1 A10	10,0	630	G 1/2"	88,0	53	100	80,0	120	115	8,5	88,0	28,0	120,0	100,0	80,0	28,0	115,0	0,74
HK MPF 100 1 G1 P10	10,0	1020	G 1/2"	-	86	100	80,0	120	115	8,5	88,0	28,0	-	-	-	-	-	0,74
HK MPF 100 1 G2 A10	10,0	630	G 3/4"	88,0	53	100	80,0	120	115	8,5	88,0	28,0	120,0	100,0	80,0	28,0	115,0	0,74
HK MPF 100 1 G2 P10	10,0	1020	G 3/4"	-	86	100	80,0	120	115	8,5	88,0	28,0	-	-	-	-	-	0,74
HK MPF 100 1 G3 A10	10,0	630	G 1"	-	53	100	80,0	120	115	8,5	88,0	28,0	-	-	-	-	-	0,74
HK MPF 100 1 G3 P10	10,0	1020	G 1"	-	86	100	80,0	120	115	8,5	88,0	28,0	-	-	-	-	-	0,74
HK MPF 100 2 G2 A10	10,0	1000	G 3/4"	-	64	150	80,0	170	115	8,5	88,0	28,0	-	-	-	-	-	0,76
HK MPF 100 2 G2 P10	10,0	1660	G 3/4"	-	110	150	80,0	170	115	8,5	88,0	28,0	-	-	-	-	-	0,76
HK MPF 100 2 G3 A10	10,0	1000	G 1"	-	64	150	80,0	170	115	8,5	88,0	28,0	-	-	-	-	-	0,76
HK MPF 100 2 G3 P10	10,0	1660	G 1"	-	110	150	80,0	170	115	8,5	88,0	28,0	-	-	-	-	-	0,76
HK MPF 100 3 G2 A10	10,0	1730	G 3/4"	-	125	225	80,0	250	115	8,5	88,0	28,0	-	-	-	-	-	0,88
HK MPF 100 3 G2 P10	10,0	1900	G 3/4"	-	220	225	80,0	250	115	8,5	88,0	28,0	-	-	-	-	-	0,88
HK MPF 100 3 G3 A10	10,0	1730	G 1"	-	125	225	80,0	250	115	8,5	88,0	28,0	-	-	-	-	-	0,88
HK MPF 100 3 G3 P10	10,0	1900	G 1"	-	220	225	80,0	250	115	8,5	88,0	28,0	-	-	-	-	-	0,88
HK MPF 180 1 G1 A10	10,0	4300	G 1.1/4"	-	230	231	89,0	250	175	10,7	129,0	35,0	-	-	-	-	-	1,86
HK MPF 180 1 G1 P10	10,0	4000	G 1.1/4"	-	280	231	89,0	250	175	10,7	129,0	35,0	-	-	-	-	-	1,86
HK MPF 400 1 G1 A10	10,0	4740	G 1.1/4"	173,5	290	178	98,5	200	220	11,5	173,5	38,5	200,0	178,0	98,5	38,5	220,0	3,42
HK MPF 400 1 G1 P10	10,0	4480	G 1.1/4"	-	370	178	98,5	200	220	11,5	173,5	38,5	-	-	-	-	-	3,42
HK MPF 400 1 G2 A10	10,0	4740	G 1.1/2"	-	290	178	98,5	200	220	11,5	173,5	38,5	-	-	-	-	-	3,42
HK MPF 400 1 G2 P10	10,0	4480	G 1.1/2"	-	370	178	98,5	200	220	11,5	173,5	38,5	-	-	-	-	-	3,42
HK MPF 400 1 G3 A10	10,0	4740	G 2"	-	290	178	98,5	200	220	11,5	173,5	38,5	-	-	-	-	-	3,42
HK MPF 400 1 G3 P10	10,0	4480	G 2"	-	370	178	98,5	200	220	11,5	173,5	38,5	-	-	-	-	-	3,42
HK MPF 400 2 G2 A10	10,0	6930	G 1.1/2"	-	450	238	98,5	250	220	11,5	173,5	38,5	-	-	-	-	-	3,48
HK MPF 400 2 G2 P10	10,0	6550	G 1.1/2"	-	610	238	98,5	250	220	11,5	173,5	38,5	-	-	-	-	-	3,48
HK MPF 400 2 G3 A10	10,0	6930	G 2"	-	450	238	98,5	250	220	11,5	173,5	38,5	-	-	-	-	-	3,48
HK MPF 400 2 G3 P10	10,0	6550	G 2"	-	610	238	98,5	250	220	11,5	173,5	38,5	-	-	-	-	-	3,48
HK MPF 400 3 G2 A10	10,0	8760	G 1.1/2"	-	540	288	98,5	310	220	11,5	173,5	38,5	-	-	-	-	-	3,68
HK MPF 400 3 G2 P10	10,0	8280	G 1.1/2"	-	675	288	98,5	310	220	11,5	173,5	38,5	-	-	-	-	-	3,68
HK MPF 400 3 G3 P10	10,0	8280	G 2"	-	675	288	98,5	310	220	11,5	173,5	38,5	-	-	-	-	-	3,68
HK MPF 750 1 F1 A10	10,0	11400	2" SAE 3000 PSI/M	-	620	430	105,0	450	220	11,5	173,5	48,5	-	-	-	-	-	5,68



Item																		
Identification	Filter mesh size (µm)	Filter area (m ²)	Line connection	Ø d (mm)	Q max. (L/min)	A (mm)	B (mm)	C (mm)	D (mm)	E (mm)	F (mm)	H (mm)	L (mm)	L1 (mm)	L2 (mm)	L3 (mm)	L6 (mm)	Weight (kg)
HK MPF 750 1 F1 P10	10,0	13450	2" SAE 3000 PSI/M	-	750	430	105,0	450	220	11,5	173,5	48,5	-	-	-	-	-	5,68
HK MPF 750 1 G1 A10	10,0	11400	G 2"	-	620	430	105,0	450	220	11,5	173,5	48,5	-	-	-	-	-	5,68

A10 with inorganic filter (10 µm), absolute filtration – P10 paper filter (10 µm), nominal filtration – Qmax - max intake volumetric flow

Accessories

HK MPF TE Pipe extension for return flow filter MPF

HK VA MAN Clogging indicator pressure gauge

Spare parts

HK MF P10 / A10 Filter element for return flow filter MPF

HK MPF GEH Housing for return flow filter MPF