

HK TA G

Tank venting filters

Properties

Design	Screw-in version
Temp. min.	-30 °C
Temp. max.	100 °C
Material	Chrome-plated steel
Air volume	HK TA 80 G: max. 450 l/min - for filter 3µm HK TA 80 G: max. 550 l/min - for filter 10µm

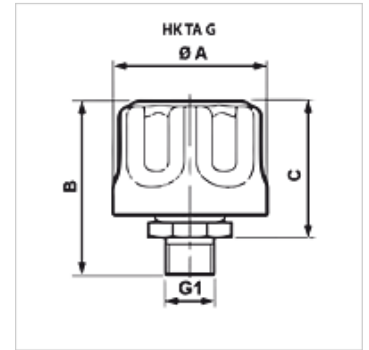

Ordering information

Available on request: Filler neck with closing tag and/or precharging valve, other sizes and types

Item

Identification	Filter mesh size (µm)	Thread	A (mm)	B (mm)	Mounting	C (mm)	Ø A (mm)	Tank bore	Weight (kg)
HK TA 80 G 03	3	G 3/4"	80	68	G 3/4"	52	80,00	G 3/4"	0,22
HK TA 80 G 10	10	-	80	68	G 3/4"	52	80,00	G 3/4"	0,22