

# HK B3/B5 230/400V

Electric motor B3/B5 230/400V

**HANSA FLEX**

## Properties

<b>Design</b>	type B3/B5 feet removable
<b>Protection IP</b>	IP 55
<b>Ambient temperature</b>	-20 °C to +40 °C
<b>Material</b>	Housing: Aluminium

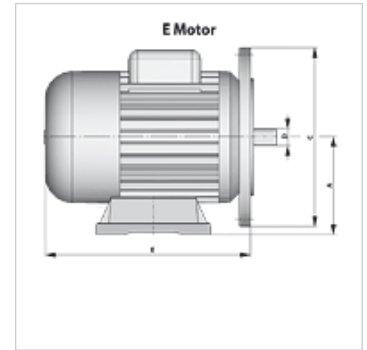

## Description

Self-cooling squirrel-cage motors

4-pin

Multi-range voltage 3-phase AC 220-240 V / 380-420 V at 50 Hz and 220-280 V / 380-480 V at 60 Hz

## Item

Identification	n 50 Hz (rpm)	n 60 Hz (rpm)	P 50 Hz (kW)	P 60 Hz (kW)	I 50 Hz (A)	LF 50 Hz	A (mm)	E (mm)	Ø C (mm)	Ø D shaft (mm)	Weight (kg)
HK 71 A4 B35 2-4 A	1410	1710	0,25	0,30	0,91	0,67	71	206	160	14	6,1
HK 71 B4 B35 2-4 A	1380	1680	0,37	0,44	1,20	0,72	71	206	160	14	6,7
HK 80 A4 B35 2-4 A	1380	1680	0,55	0,66	1,58	0,74	80	228	200	19	8,9

P 50 Hz = nominal output at 400 V/50 Hz – P 60 Hz = nominal output at 400 V/60 Hz – n 50 Hz = nominal speed at 400 V/50 Hz – n 60 Hz = nominal speed at 400 V/60 Hz – I 50 Hz = nominal current at 400 V/50 Hz – LF 50 Hz = cos phi power factor at 50 Hz

## Additional elements

HK MPK Selection chart for motor/pump combination for gear pumps