

08BS 9 FPM

Usit ring centred 08BS9-FPM

Properties

Design	Usit ring
Construction type	self-centring
Temp. min.	-20 °C
Temp. max.	200 °C
Installation	with screws and connecting pieces
Material	1) FPM (2) Cadmium-plated or passivated carbon steel

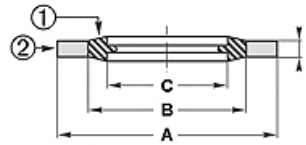

Toleranz / Tolerance				
Baureihe / Range	A	B	C	E
9; 92; 93	+0,13 0	+/-0,13	+/-0,13	+/-0,15

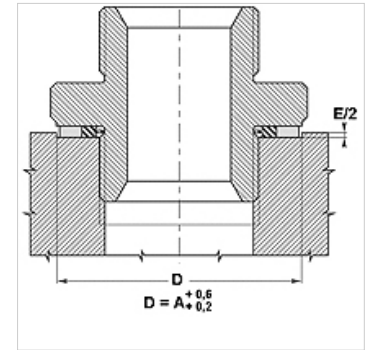

Description

Perfect tightness.

Numerous applications possible in static and dynamic sectors, no distortion possible with rotational movements.

Numerous applications depending on material.

Available for metric, Whitworth and BSP threads.

Item

Identification	for thread	for thread	A (mm)	B (mm)	A (mm)	C (mm)	B (mm)	C (mm)	E (mm)	Pressure PB (bar)
UR 10.7-18-1.5 FKM	-	-	10,7	18,0	-	1,5	-	-	-	-
08BS 921 FPM	G 1/4"	1/2 inch	-	-	20,57	-	15,21	13,74	2,10	1550
08BS 923 FPM	G 3/8"	-	-	-	23,80	-	18,75	17,28	2,10	1260
08BS 925 FPM	G 1/2"	13/16 inch	-	-	28,58	-	23,01	21,54	2,40	1150
08BS 927 FPM	G 3/4"	1 inch	-	-	34,93	-	28,53	27,05	2,40	1060
08BS 929 FPM	G 7/8"	1 3/16 inch	-	-	38,10	-	32,29	30,81	2,40	900
08BS 930 FPM	G 1"	1 5/16 inch	-	-	42,80	-	36,88	33,89	2,50	790
08BS 932 FPM	G 1.1/4"	1 5/8 inch	-	-	52,38	-	45,93	42,93	2,50	690