

## Properties

<b>Design</b>	Pre-assembly sockets
<b>Material</b>	Hardened tool steel
<b>Surface</b>	phosphate treated

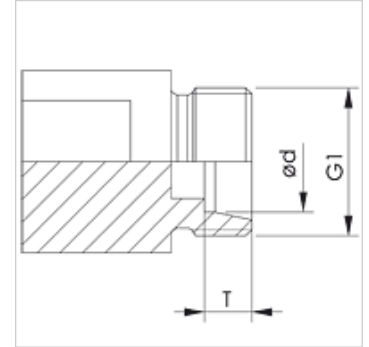

## Note

The VOM WR is used for assembling the UEM WR

## Item

Identification	Series	Ø d (mm)	G1	T (mm)
VOM NW 04 HL WR	L	6	M 12 x 1.5	7,0
VOM NW 06 HL WR	L	8	M 14 x 1.5	7,0
VOM NW 08 HL WR	L	10	M 16 x 1.5	7,0
VOM NW 10 HL WR	L	12	M 18 x 1.5	7,0
VOM NW 13 HL WR	L	15	M 22 x 1.5	7,0
VOM NW 16 HL WR	L	18	M 26 x 1.5	7,5
VOM NW 20 HL WR	L	22	M 30 x 2	7,5
VOM NW 25 HL WR	L	28	M 36 x 2	7,5
VOM NW 32 HL WR	L	35	M 45 x 2	10,5
VOM NW 40 HL WR	L	42	M 52 x 2	11,0
VOM NW 03 HS WR	S	6	M 14 x 1.5	7,0
VOM NW 04 HS WR	S	8	M 16 x 1.5	7,0
VOM NW 06 HS WR	S	10	M 18 x 1.5	7,5
VOM NW 08 HS WR	S	12	M 20 x 1.5	7,5
VOM NW 13 HS WR	S	16	M 24 x 1.5	8,5
VOM NW 16 HS WR	S	20	M 30 x 2	10,5
VOM NW 20 HS WR	S	25	M 36 x 2	12,0
VOM NW 25 HS WR	S	30	M 42 x 2	13,5
VOM NW 32 HS WR	S	38	M 52 x 2	16,0

Series: LL = Very light L = Light S = Heavy

## Accessory for following products

UEM FM WR	WALRING union nut
-----------	-------------------