

HK TA B

Tank venting and filler filters

Properties

Design Flange mounting on the tank, with filler screen

Material Chrome-plated steel, cork gasket

Air volume HK TA 46 B: max. 150 l/min - for filter 3µm
HK TA 46 B: max. 200 l/min - for filter 10µm
HK TA 80 B: max. 450 l/min - for filter 3µm
HK TA 80 B: max. 550 l/min - for filter 10µm

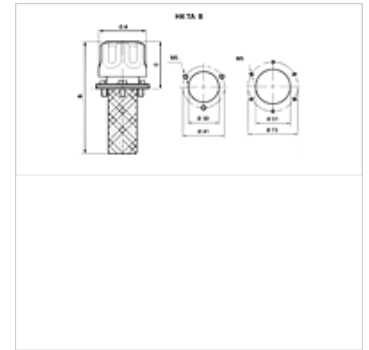

Ordering information

Available on request: Filler neck with closing tag and/or precharging valve, other sizes and types

Item

Identification	Filter mesh size (µm)	Air volume (L/min)	A (mm)	B (mm)	Mounting	C (mm)	Bolt circle (mm)	Tank bore	Weight (kg)
HK TA 46 B 03	3	150	46	111	3 x M5	48	41	30 mm	0,10
HK TA 46 B 10	10	-	46	111	3 x M5	48	41	30 mm	0,10
HK TA 80 B 03 1	3	-	80	134	6 x M5	56	73	51 mm	0,28
HK TA 80 B 10 1	10	-	80	134	6 x M5	56	73	51 mm	0,28
HK TA 80 B 03 2	3	-	80	204	6 x M5	56	73	51 mm	0,32
HK TA 80 B 10 2	10	-	80	204	6 x M5	56	73	51 mm	0,32