

HK B3/B5 400/690V IE2

Electric motor B3/B5 400/690V IE2

HANSA FLEX

Properties

Design	type B3/B5 feet removable Feet fixed (from HK160M4 ***)
Protection IP	IP 55
Ambient temperature	-20 °C to +40 °C
Material	Housing: Aluminium Housing: Grey cast iron (from HK160M4B354-6IE2)

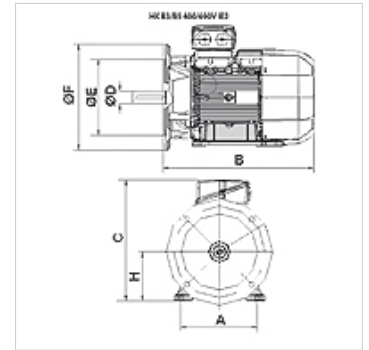

Description

Self-cooling squirrel-cage energy-saving motors
High efficiency IE2 - IEC60034-30:2008
Rated voltage 400/690V 50Hz, 460V 60Hz; 4-pin
Voltage tolerance +- 5%
Above 11 kW incl. temperature protection (PTC thermistor)

Item

Identification	n 50 Hz (rpm)	n 60 Hz (rpm)	P 50 Hz (kW)	P 60 Hz (kW)	I 50 Hz (A)	LF 50 Hz	A (mm)	H (mm)	B (mm)	C (mm)	Ø D shaft (mm)	Ø E (mm)	Ø F (mm)	η (IE2) %	Weight (kg)
HK 112M4 B35 4-6 IE2	1460	1760	4,00	4,60	8,20	0,81	190	112	375	302	28	180	250	85,5	29,0
HK 132SB4 B35 4-6 IE2	1460	1760	5,50	6,30	11,20	0,80	216	132	390	342	38	230	300	87,7	42,0

P 50 Hz = nominal output at 400 V/50 Hz – P 60 Hz = nominal output at 400 V/60 Hz – n 50 Hz = nominal speed at 400 V/50 Hz – n 60 Hz = nominal speed at 400 V/60 Hz – I 50 Hz = nominal current at 400 V/50 Hz – LF 50 Hz = cos phi power factor at 50 Hz – η (IE2) = efficiency to IE2 in % (at full load)