

# DAMPF AR

Steam fittings AR, with steel clamping shell

**HANSA FLEX**

## Properties

<b>Application</b>	Hot water or saturated steam applications
<b>Connection 1</b>	BSP nut thread
<b>Sealing form 1</b>	flat sealing
<b>Operating pressure</b>	up to 18 bar
<b>Short code</b>	DKR flat
<b>Standard</b>	DIN EN 14423 thread standard ISO 228/DIN 2999
<b>Scope of supply</b>	with clamping shells and seal
<b>Temp. range</b>	saturated steam up to +210 °C hot water up to +120 °C
<b>Material</b>	Steel Pressed brass clamping shells
<b>Surface</b>	electro galvanised

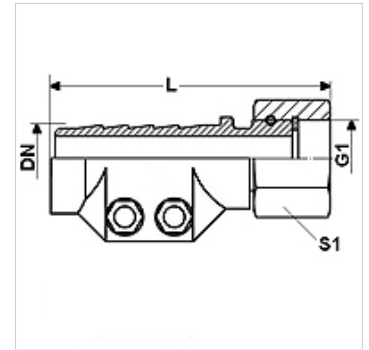

## Item

Identification	DN	Size	Inches	G1	L (mm)	Clamping range (mm)	S1 (mm)
DAMPF 13 AR	12	8	1/2"	G 1/2" -14	88,0	24 - 26	27
DAMPF 19 AR	19	12	3/4"	G 3/4" -14	92,0	32 - 34	32
DAMPF 25 AR	25	16	1"	G 1" -11	93,0	39 - 41	41
DAMPF 32 AR	31	20	1.1/4"	G 1.1/4" -11	97,5	47 - 50	50
DAMPF 38 AR	38	24	1.1/2"	G 1.1/2" -11	120,0	53 - 56	55
DAMPF 50 AR	51	32	2"	G 2" -11	131,0	67 - 69	70

DN = Nominal diameter, nominal width

## Product versions

<b>DAMPF AR MG</b>	Steam fittings AR, with clamping brass shell, Brass
<b>DAMPF AR VA</b>	Steam fittings AR, with stainless steel clamping shell, Stainless steel