

DAMPF AR MG

Steam fittings AR, with clamping brass shell

HANSA FLEX

Properties

Application	Hot water or saturated steam applications
Connection 1	BSP nut thread
Sealing form 1	flat sealing
Operating pressure	up to 18 bar
Short code	DKR flat
Standard	DIN EN 14423 thread standard ISO 228/DIN 2999
Scope of supply	with clamping shells and seal
Temp. range	saturated steam up to +210 °C hot water up to +120 °C
Material	Brass Pressed brass clamping shells

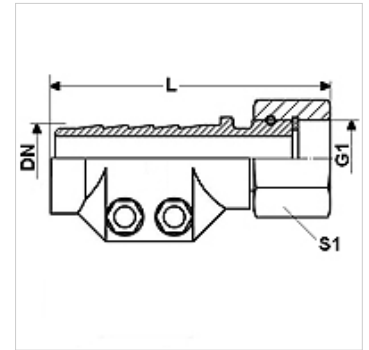

Item

Identification	DN	Size	Inches	G1	L (mm)	Clamping range (mm)	S1 (mm)
DAMPF 13 AR MG	12	8	1/2"	G 1/2" -14	88,0	24 - 26	27
DAMPF 19 AR MG	19	12	3/4"	G 3/4" -14	92,0	32 - 34	32
DAMPF 25 AR MG	25	16	1"	G 1" -11	93,0	39 - 41	41
DAMPF 32 AR MG	31	20	1.1/4"	G 1.1/4" -11	97,5	47 - 50	-
DAMPF 38 AR MG	38	24	1.1/2"	G 1.1/2" -11	120,0	53 - 56	55
DAMPF 50 AR MG	51	32	2"	G 2" -11	131,0	67 - 69	70

DN = Nominal diameter, nominal width

Product versions

DAMPF AR	Steam fittings AR, with steel clamping shell, Steel
DAMPF AR VA	Steam fittings AR, with stainless steel clamping shell, Stainless steel