

## Properties

<b>Design</b>	combinable with coupling HK SPIDEX Z
<b>Material</b>	Aluminium
<b>Use</b>	For gear pumps size 0 to size 3

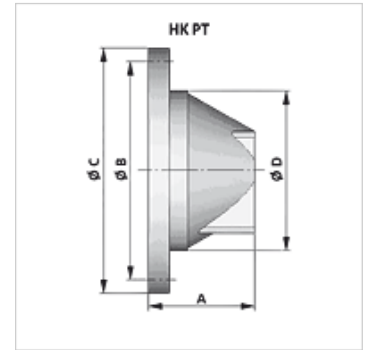
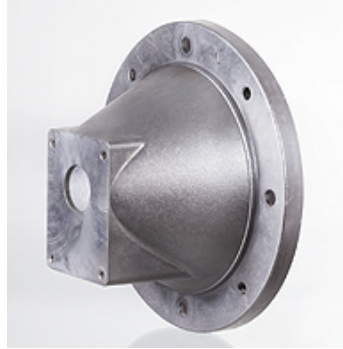

## Description

Centring for motor and pump shaft

## Item

Identification	A (mm)	Ø B (mm)	Ø C (mm)	Ø D (mm)	Flange for pump connection	Pump	Motor	Weight (kg)
HK PT RV 160 70 468	70,00	130	160	110	Two-hole flange 66	BG0/cyl. shaft	BG71	0,5
HK PT RV 160 80 448 ZFV	80,00	130	160	110	71.9 x 52.4	BG1/shaft 1:8	BG71	0,5
HK PT RV 200 80 468	80,00	165	200	145	Two-hole flange 66	BG0/cyl. shaft	BG80	0,7
HK PT RV 200 80 448	80,00	165	200	145	71.9 x 52.4	BG1/shaft 1:8	BG80	0,7
HK PT RV 200 90 448	90,00	165	200	145	71.9 x 52.4	BG1/shaft 1:8	BG90	0,7
HK PT RV 200 96 446 ZFV	96,00	165	200	145	96.2 x 71.5	BG2/shaft 1:8	BG80/90	0,7
HK PT RV 200 96 441	96,00	165	200	145	100 x 72 (Ø80)	BG2 / shaft 1:5	BG80/90	0,8
HK PT RV 250 110 448	110,00	215	250	190	71.9 x 52.4	BG1/shaft 1:8	BG100/112	1,3
HK PT RV 250 110 446	110,00	215	250	190	96.2 x 71.5	BG2/shaft 1:8	BG100/112	1,3
HK PT RV 250 110 441	110,00	215	250	190	100 x 72 (Ø80)	BG2 / shaft 1:5	BG100/112	1,2
HK PT RV 250 115 465	115,00	215	250	190	128 x 98	BG3/shaft 1:8	BG100/112	1,2
HK PT RV 300 130 446	130,00	265	300	234	96.2 x 71.5	BG2/shaft 1:8	BG132	2,0
HK PT RV 300 130 441	130,00	265	300	234	100 x 72 (Ø80)	BG2 / shaft 1:5	BG132	1,9
HK PT RV 300 144 465	144,00	265	300	234	128 x 98	BG3/shaft 1:8	BG132	2,0
HK PT RV 350 173 446	173,00	300	350	260	96.2 x 71.5	BG2/shaft 1:8	BG160	3,4
HK PT RV 350 173 441	173,00	300	350	260	100 x 72 (Ø80)	BG2 / shaft 1:5	BG160	2,7
HK PT RV 350 173 465	173,00	300	350	260	128 x 98	BG3/shaft 1:8	BG160/180	3,4

## Accessories

HK DRV	Damping ring
HK DPT	Gasket for pump mounts

## Additional elements

HK MPK	Selection chart for motor/pump combination for gear pumps
--------	---