

HK HM BMT

BMT CN geroller motor

Properties

Connection	Oil fittings: A + B = G 3/4"; leak oil = G 1/4"
Design	Economy variant / short shaft always connect drain line Four hole flange bolt circle 160 Shaft Ø 40mm, length 60mm
Intake and return pressure with leak oil line max.	210 bar

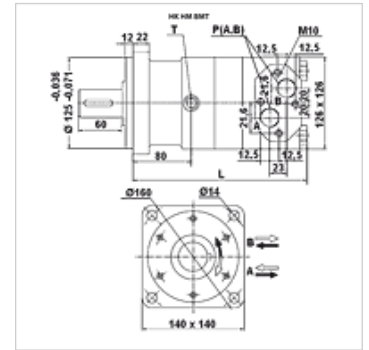

Note

It is generally recommended that the leak oil line is connected!

Item

Identification	Flow rate max. (L/min)	Displacement (cc)	Speed min. (rpm)	Speed max. (rpm)	Torque max. (N-m)	Pressure drop max. (bar)	Pmax. at 0-100 rpm (bar)	Pmax. at 100-300 rpm (bar)	Pmax. at 300 rpm (bar)	L (mm)	Weight (kg)
HK HM BMT 160	100	158,8	10	625	450	200	75	40	20	210	20,3
HK HM BMT 200	125	200,8	10	625	560	200	75	40	20	215	20,8
HK HM BMT 250	125	252,2	10	500	710	200	75	40	20	220	21,4
HK HM BMT 315	125	317,5	10	280	900	200	75	40	20	227	22,4
HK HM BMT 400	125	401,6	10	305	1000	180	75	40	20	236	23,0
HK HM BMT 500	125	535,5	10	240	1120	160	75	40	-	255	24,0

max. pressure on shaft seal (without leak oil line) or pressure in leak oil line – Values for torque and pressure drop apply for continuous operation – pmax = max. pressure

Accessories

HK V0 590 Shock valve

Spare parts

HK HM BM DS Seal kit for hydraulic planetary motor CN