

K-DVST OHNE REGLER

Pressure booster without regulator

HANSA FLEX

Properties

Input pressure	2 - 10 bar
Output pressure	Max. 20 bar (regulated: max. 16 bar)
Temp. range	-10 °C to +50 °C (40 mm bore), -10 °C to +60 °C (63 mm bore)
Media	Filtered, unlubricated or lubricated compressed air (if lubrication is used, it must be continuous)
Sealant	NBR
Pressure regulators	With plastic body
Housing	Aluminium, anodised
Pipe	Anodised aluminium jacket
Installation	Any position, with 4 mounting holes
P2:P1	2:1

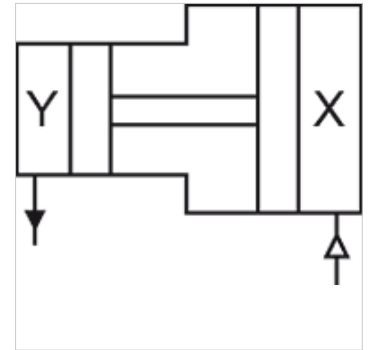

Note

For information about calculating the filling times for different tank sizes, refer to the above-mentioned data sheet available on our website
Further information on request

Description

Pressure multipliers (boosters) allow a separate compressed air store with up to double pressure to be installed for selected devices in a compressed air system without an external energy source, i.e. it is possible to work with a maximum pressure of 20 bar in a standard 10 bar system (maximum ratio 2:1). This is achieved using a double piston, which is operated by a combination of integrated check valves in such a way that the booster works automatically until the target pressure is reached in a compressed air tank and is then automatically switched off. A tank is always required to build up the pressure and store the compressed air!

Additional information

Fixing bracket with nut

Item

Identification	Connection	Ø piston (mm)	H (mm)	L (mm)
K- 07 25 08 64	G 1/8	40,0	64,0	194,0
K- 07 25 08 66	G 3/8	63,0	98,0	290,0

Accessories

K-ZUBEH ERSATZ LUFT BOOSTER Accessories / spare parts for Air-air-multiplier (booster)