

# K-RUNDZYLINDER DOPP M D

Rundzylinder, doppeltwirkend (mit Magnet, mit einstellbarer Dämpfung)

**HANSA FLEX**

## Properties

<b>Media</b>	Filtered, unlubricated or lubricated compressed air. If lubrication is used, it must be continuous.
<b>Working pressure</b>	Max. 10 bar
<b>Set pressure</b>	0,8 bar (Ø 8 bis Ø 12), 0,6 bar (Ø 16 bis Ø 25)
<b>Temp. range</b>	-10 °C to +80 °C
<b>Design</b>	Flanged joint between stainless steel barrel and heads
<b>Piston rod</b>	C45 steel, hard chrome-plated
<b>Pipe</b>	Stainless steel 1.4301
<b>Piston</b>	Synthetic (acetal) resin
<b>Sealant</b>	NBR

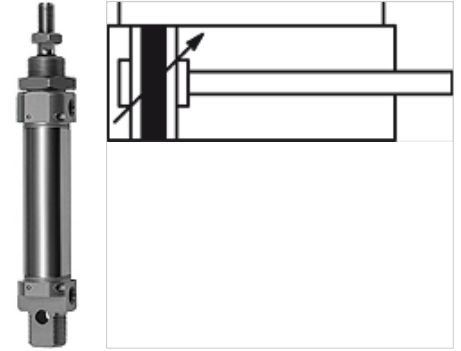

## Note

Maximum recommended stroke: Double-acting: Ø 8 - Ø 10 = 100 stroke, Ø 12 - Ø 16 = 200 stroke, Ø 20 - Ø 25 = 250 stroke

Single-acting: Ø 8 - Ø 25 = 50 stroke. Longer stroke lengths can cause operational malfunctions.

Further information on request

## Description

Single and double-acting cylinders, with magnetic piston.

## Additional information

Important: The scope of supply does not include a connector. Please order separately.

## Item

Identification	Ø piston	Stroke (mm)	Connection	Thread piston rod
K- 07 15 24 89	16 mm	10	M 5	M 6
K- 07 15 24 90	16 mm	25	M 5	M 6
K- 07 15 24 91	16 mm	50	M 5	M 6
K- 07 15 24 92	16 mm	80	M 5	M 6
K- 07 15 24 93	16 mm	100	M 5	M 6
K- 07 15 24 94	16 mm	125	M 5	M 6
k- 07 15 24 95	16 mm	160	M 5	M 6
K- 07 15 24 96	16 mm	200	M 5	M 6
K- 07 15 24 97	20 mm	10	G 1/8	M 8
K- 07 15 24 98	20 mm	25	G 1/8	M 8
K- 07 15 24 99	20 mm	50	G 1/8	M 8
K- 07 15 25 00	20 mm	80	G 1/8	M 8
K- 07 15 25 01	20 mm	100	G 1/8	M 8
K- 07 15 25 02	20 mm	125	G 1/8	M 8
K- 07 15 25 03	20 mm	160	G 1/8	M 8
K- 07 15 25 04	20 mm	200	G 1/8	M 8
K- 07 15 25 05	20 mm	250	G 1/8	M 8
K- 07 15 25 06	25 mm	10	G 1/8	M 10 x 1.25
K- 07 15 25 07	25 mm	25	G 1/8	M 10 x 1.25
K- 07 15 24 88	25 mm	50	G 1/8	M 10 x 1.25
K- 07 15 25 08	25 mm	80	G 1/8	M 10 x 1.25
K- 07 15 25 09	25 mm	100	G 1/8	M 10 x 1.25
K- 07 15 25 10	25 mm	125	G 1/8	M 10 x 1.25
K- 07 15 25 11	25 mm	160	G 1/8	M 10 x 1.25
K- 07 15 25 12	25 mm	200	G 1/8	M 10 x 1.25
K- 07 15 25 13	25 mm	250	G 1/8	M 10 x 1.25